



Absolutely The Best Crane Mats In The World.

This document is stored and available in the Raptor Tech Technical Document Repository.

To help our customers understand certain critical data points that factor into purchasing crane mats, Raptor Tech maintains a repository of technical documents with data from all major crane manufacturers.

You can visit Raptor Tech's repository to get crane specifications and technical details for crane models in addition to this model at:

<https://library.steelcranemats.com>

Thank You for Visiting the [SteelCraneMats.com](https://library.steelcranemats.com) Technical Specifications Document Repository.

Technical Data

Specifications & Capacities

HTC **3140**
LB

Telescopic Boom Truck Crane
140 US ton
120 metric ton

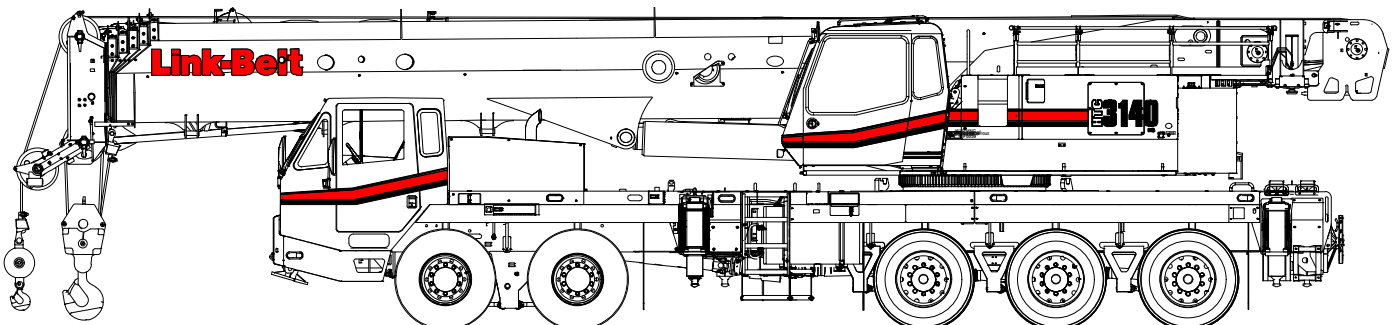

CAUTION: This material is supplied for reference use only. Operator must refer to in-cab Crane Rating Manual and Operator's Manual to determine allowable crane lifting capacities and assembly and operating procedures.

Table Of Contents

Boom, Attachments, and Upper Structure	1
Boom	1
Boom Wear Pads	1
Boom Head	1
Boom Elevation	1
Auxiliary Lifting Sheave – Optional	1
Hook Blocks and Balls – Optional	1
Fly – Optional	1
Fly Extensions – Optional	1
Upper Operator’s Cab and Controls	2
Swing	3
Central Lubrication System	3
Electrical	3
Load Hoist System	4
Load Hoist Performance	4
2M Main (Front) and Optional Auxiliary (Rear) Winches	4
Hydraulic System	5
Pump Drive	5
Fuel Tank	5
Engine	5
Counterweight	5
Carrier	7
General	7
Outriggers	7
Steering and Axles	7
Suspension	7
Ground Control Outrigger/Suspension Controls	7
Tires and Wheels	7
Brakes	7
Central Lubrication System	7
Electrical	7
Engine	8
Transmission	8
Fuel Tank	8
Hydraulic System	8
Pump Drive	8
Carrier Speeds and Gradeability	8
Lower Cab and Controls	9
Additional Equipment	10
Axle Loads	11
Axle Loads with 2–Axle or 3–Axle Boom Dolly	12

General Dimensions	13
Working Range Diagram	14
Boom Extend Modes	15
Main Boom Lift Capacity Charts – Standard	16
20,000 lb Counterweight – Fully Extended Outriggers – 360° Rotation	16
Main Boom Lift Capacity Charts – Optional	17
60,000 lb Counterweight – Fully Extended Outriggers – 360° Rotation	17
Main Boom Length (ft)	17
Manual Offset Fly Attachment Lift Capacity Charts – Optional	18
20,000 lb Counterweight – Fully Extended Outriggers – 360° Rotation	18
Main Boom + 10 ft Manual Offset Fly (2°, 15°, 30°, 45° Offsets)	18
60,000 lb Counterweight – Fully Extended Outriggers – 360° Rotation	19
Main Boom + 10 ft Manual Offset Fly (2°, 15°, 30°, 45° Offsets)	19
20,000 lb Counterweight – Fully Extended Outriggers – 360° Rotation	20
155.0 ft Main Boom Length + 31 ft & 55 ft Manual Offset Fly (2°, 15°, 30°, 45° Offsets)	20
60,000 lb Counterweight – Fully Extended Outriggers – 360° Rotation	21
155.0 ft Main Boom Length + 31 ft & 55 ft Manual Offset Fly (2°, 15°, 30°, 45° Offsets)	21
155.0 ft Main Boom Length + 73 ft, 91 ft & 109 ft Manual Offset Fly (2°, 15°, 30°, 45° Offsets)	22
20,000 lb Counterweight – Fully Extended Outriggers – 360° Rotation	23
195.3 ft Main Boom Length + 31 ft & 55 ft Manual Offset Fly (2°, 15°, 30°, 45° Offsets)	23
60,000 lb Counterweight – Fully Extended Outriggers – 360° Rotation	24
195.3 ft Main Boom Length + 31 ft & 55 ft Manual Offset Fly (2°, 15°, 30°, 45° Offsets)	24
195.3 ft Main Boom Length + 73 ft, 91 ft & 109 ft Manual Offset Fly (2°, 15°, 30°, 45° Offsets)	25
Hydraulic Offset Fly Attachment Lift Capacity Charts – Optional	26
20,000 lb Counterweight – Fully Extended Outriggers – 360° Rotation	26
Main Boom + 10 ft Hydraulic Offset Fly (2°–45° Offsets)	26
60,000 lb Counterweight – Fully Extended Outriggers – 360° Rotation	27
Main Boom + 10 ft Hydraulic Offset Fly (2°–45° Offsets)	27
20,000 lb Counterweight – Fully Extended Outriggers – 360° Rotation	28
155.0 ft Main Boom Length + 31 ft & 55 ft Hydraulic Offset Fly (2°–45° Offsets)	28
60,000 lb Counterweight – Fully Extended Outriggers – 360° Rotation	29
155.0 ft Main Boom Length + 31 ft & 55 ft Hydraulic Offset Fly (2°–45° Offsets)	29
155.0 ft Main Boom Length + 73 ft, 91 ft & 109 ft Hydraulic Offset Fly (2°–45° Offsets)	30
20,000 lb Counterweight – Fully Extended Outriggers – 360° Rotation	31
195.3 ft Main Boom Length + 31 ft & 55 ft Hydraulic Offset Fly (2°–45° Offsets)	31
60,000 lb Counterweight – Fully Extended Outriggers – 360° Rotation	32
195.3 ft Main Boom Length + 31 ft & 55 ft Hydraulic Offset Fly (2°–45° Offsets)	32
195.3 ft Main Boom Length + 73 ft, 91 ft & 109 ft Hydraulic Offset Fly (2°–45° Offsets)	33

Boom, Attachments, and Upper Structure

■ Boom

Design — Six section, formed construction of extra high tensile steel consisting of one base section and five telescoping sections. The two plate design of each section has multiple longitudinal bends for superior strength. Each telescoping section extends independently by means of one double-acting, single stage hydraulic cylinder with integrated holding valves.

Boom

- 42.3–195.3 ft (12.9–59.5m) six section boom
- Integral boom dolly connection
- Five boom extend modes (EM1 through EM5), controlled from the operator's cab, provide superior capacities by varying the extension of the telescoping sections:
 - EM1 extends to 195.3 ft (59.5m)
 - EM2 extends to 180.3 ft (55.0m)
 - EM3 extends to 155.0 ft (47.2m)
 - EM4 extends to 129.6 ft (39.5m)
 - EM5 extends to 103.7 ft (31.6m)
- Mechanical boom angle indicator
- Wind speed indicator
- Maximum tip height for each extend mode is:
 - EM1 is 204 ft (62.2m)
 - EM2 is 189 ft (57.6m)
 - EM3 is 164 ft (50.0m)
 - EM4 is 139 ft (42.4m)
 - EM5 is 113 ft (34.4m)

Boom Wear Pads

- Wear pads with Teflon inserts that self-lubricate the boom sections
- Bottom wear pads are universal for T2, T3, T4, and T5 boom sections
- Bottom wear pads are universal for the base and T1 boom sections
- Top wear pads are universal for all boom sections

Boom Head

- Six 16.38 in (41.6cm) root diameter nylon sheaves to handle up to twelve parts of line
- Easily removable wire rope guards
- Rope dead end lugs on each side of the boom head
- Boom head is designed for quick-reeve of the hook block

Boom Elevation

- One double acting hydraulic cylinder with integral holding valve
- Boom elevation: -2.5° to 80°

Auxiliary Lifting Sheave — Optional

- Single 16.38 in (41.6m) root diameter nylon sheave
- Easily removable wire rope guards
- Does not affect erection of the fly or use of the main head sheaves

Hook Blocks and Balls — Optional

- 140 ton (127.0mt) 7 sheave quick-reeve hook block with safety latch
- 100 ton (90.7mt) 6 sheave quick-reeve hook block with safety latch
- 80 ton (72.6mt) 5 sheave quick-reeve hook block with safety latch
- 50 ton (45.4mt) 4 sheave quick-reeve hook block with safety latch
- 35 ton (31.8mt) 1 sheave quick-reeve hook block with safety latch
- 12 ton (10.9mt) hook ball (swivel) with safety latch

Fly — Optional

- 31–55 ft (9.4–16.7m) two piece bi-fold lattice fly, stowable, offsettable to 2° , 15° , 30° , and 45° . Maximum tip height is 258 ft (78.6m).
- 10–31 ft–55 ft (3.0–9.4–16.7m) three piece bi-fold lattice fly, stowable, offsettable to 2° , 15° , 30° , and 45° . Maximum tip height is 258 ft (78.6m).
- 10 ft–31 ft–55 ft (3.0–9.4–16.7m) three piece bi-fold lattice fly, stowable, hydraulically offsettable to 2° through 45° . Maximum tip height is 258 ft (78.6m).

Fly Extensions — Optional

- One 18 ft (5.5m) lattice extension, equipped with two 16.38 in (41.6cm) root diameter nylon sheaves, to be mounted between the boom head and fly options. Maximum tip height is 276 ft (84.1m). Minimum of 32,000 lb (14.5t) of counterweight required.
- Two 18 ft (5.5m) lattice extensions, one equipped with two 16.38 in (41.6cm) root diameter nylon sheaves, to be mounted between the boom head and fly options. Maximum tip height is 293 ft (89.3m). Minimum of 32,000 lb (14.5t) of counterweight required.
- Three 18 ft (5.5m) lattice extensions, one equipped with two 16.38 in (41.6cm) root diameter nylon sheaves, to be mounted between the boom head and fly options. Maximum tip height is 311 ft (94.8m). Minimum of 32,000 lb (14.5t) of counterweight required.

■ Upper Operator's Cab and Controls

Environmental Cab – Fully enclosed, one person cab of galvanneal steel structure with acoustical insulation.

Equipped with:

- Tilting cab up to 20°
- Tinted and tempered glass windows
- Five way adjustable, cushioned seat with headrests, and seat belt
- Extra—large fixed front window with windshield wiper and washer
- Swing up roof window with windshield wiper
- Sliding left side door with large fixed window
- Sliding right side window for ventilation
- Engine dependent warm – water heater with air ducts for front windshield defroster and cab floor
- Defroster fan for the front window
- Bubble level
- Circulating fan
- Sun screen
- Cup holder
- Fire extinguisher
- Left side viewing mirror
- Two position travel swing lock
- AM/FM Radio

Air Conditioning – Integral with cab heating system utilizing the same ventilation outlets

Armrest Controls – Two dual axis electronic joystick controllers or optional single axis electronic controllers for:

- Swing
- Boom hoist
- Main front winch
- Auxiliary rear winch – optional
- Drum rotation indication
- Drum rotation indicator activation switch
- Winch high/low speed disable switch(es)
- Cab heater and A/C controls
- Throttle lock switch
- Throttle set/resume switch
- Cab tilt switch
- Counterweight handling switch
- Warning horn button
- Swing park brake

Foot Controls

- Boom Telescope
- Swing brake
- Engine throttle

Right Front Console – Controls and indicators for:

- Warning horn button
- Function disable switch
- Cab floodlights switch
- Console dimmer switch
- 2–12 volt accessory outlet (Switched & Unswitched)
- Emergency engine shutdown
- Windshield wiper/washer switch
- Outrigger keypad
- Upper ignition switch
- Lower ignition switch
- Boom floodlights switch – optional
- Rotating beacon/strobe light switch – optional
- Hydraulic offset fly switch – optional

Camera Display – Located on dash console

- Displays right side of upper
- Displays main and auxiliary winches

Cab Instrumentation – Ergonomically positioned LCD display, CANBUS instrumentation for crane operation including:

- Tachometer & Engine speed value (RPM)
- Coolant temperature level gauge, warning indicator & value (F)
- Hydraulic temperature level gauge, warning indicator & value (F)
- Fuel level gauge & low level warning indicator
- DEF level gauge & low level warning indicator⁽¹⁾
- Engine Diagnostics & fault codes
- Swing park brake warning indicator
- Engine oil pressure warning indicator
- Charge filter warning indicator
- Stop engine indicator
- Check engine indicator
- Wait to start indicator
- High exhaust temperature indicator
- Exhaust system cleaning indicator
- Exhaust system cleaning Disabled indicator
- Engine air filter high restriction indicator
- Battery voltage warning indicator & value (V)
- Fuel rate value (gal/hr)
- Engine hours (Hrs)
- Engine load value (%)
- Exhaust system cleaning initiate switch
- Exhaust system cleaning inhibit switch
- Outrigger level indicator
- Electronic Control Diagnostics & mode indicator
- Service interval indicators
 - Hydraulic oil life indicator
 - Engine oil indicator
 - Next service indicator – user defined
- Carrier engine gauges and indicators
- Fine metering mode indicator, function set & %
- Third wrap indicator activation & setup

Diagnostic Center – Located on the left side of the front panel below the windshield

- Engine diagnostic
- RCL CANBUS diagnostic
- Boom CANBUS diagnostic
- Crane Controller USB diagnostic
- RCL controller USB diagnostic
- Manual crane control connection

Manual Telescope Control – Located on the upper work platform

- Manual boom telescope control connection

⁽¹⁾ (Tier 4f / Stage IV engine only)

Link-Belt Pulse – The Link-Belt in-house designed, total crane operating system that utilizes the display as a readout and operator interface for the following systems:

- **Rated capacity limiter** – LCD graphic audio – visual warning system integrated into the dash with anti – two block and function limiter. Operating data includes:
 - Crane configuration
 - Boom length and angle
 - Boom head height
 - Allowed load and % of allowed load
 - RCL light bar
 - Boom angle
 - Radius of load
 - Actual load
 - Wind speed
 - Unit Conversion
 - Multiple language capabilities
 - Highlighted unit of measurement on working screen
 - Active pin/latch status
 - Telescope operation displayed in real time
 - Counterweight installation/removal
 - Third wrap indicator
 - Diagnostics
 - Operator settable alarms (include):
 - Maximum and minimum boom angles
 - Maximum tip height
 - Maximum boom length
 - Swing left/right positions
 - Operator defined area (imaginary plane)
 - Outrigger position sensing
- **Telematics** – Cellular–based data logging and monitoring system that provides:
 - Location and operational settings
 - Routine maintenance
 - Crane and engine monitoring
 - Diagnostic and fault codes
- **Extend control module (ECM)**
 - Controls the extend modes
 - Diagnostics
- **Electronic controllers**
 - Controls all load lifting functions
 - Diagnostics
- **Fine metering**
 - Controls the initial reaction speeds of the main and auxiliary winches, boom hoist, and swing functions
 - Diagnostics

Integrated Third Wrap Indicator – Optional – Link–Belt Pulse color display visually and audibly warns the operator when the wire rope is on the first/bottom layer and when the wire rope is down to the last three wraps.

Integrated Third Wrap Function Kickout – Optional – Link–Belt Pulse color display visually and audibly warns the operator when the wire rope is on the first/bottom layer and provides a function kickout when the wire rope is down to the last three wraps.

Internal RCL Light Bar – Visually informs the operator when crane is approaching maximum load capacity with a series of green, yellow, and red lights.

External RCL Light Bar – Optional – Visually informs the ground crew when crane is approaching maximum load capacity with a series of green, yellow, and red lights.

■ Swing

Motor/Planetary – Bi–directional hydraulic swing motor mounted to a planetary reducer for 360° continuous smooth swing at 1.5 rpm.

Swing Park Brake – 360°, electric over hydraulic, (spring applied/hydraulic released) multi–disc brake mounted on the speed reducer. Operated by a switch from the operator’s cab.

Swing Brake – 360°, foot operated, hydraulic applied disc brake mounted to the speed reducer.

Swing Lock – Two–position swing lock (boom over front or rear) operated from the operator’s cab.

360° Positive Swing Lock – Optional – Meets New York City requirement.

■ Central Lubrication System

Automated lubrication unit that injects grease into the turntable bearing, boom hoist cylinder pins, boom foot pins, house lock (2–position), and cab tilt cylinder. Activated by a timer on the ignition switch.

■ Electrical

Two 12V batteries provide operation and starting. CANBUS wiring and components.

Swing Alarm – Audio/visual warning device signals when the upper is swinging.

Lights

- Two LED working lights on the front of the cab
- One LED working light on the top of the cab – optional
- One amber strobe beacon on top of the cab – optional
- Boom floodlight – Single – optional
- Boom floodlight – Dual – optional
- Boom floodlight – High intensity remote controlled – optional

Power Panel – Sealed power panel containing:

- Battery disconnects
- Hour meter
- Fuses, circuit breakers, relays, diodes, resistors
- Control modules

■ Load Hoist System

Load Hoist Performance

Main (Front) and Auxiliary (Rear) Winches — 7/8 in (22mm) Rope										
Layer	Maximum Line Pull		Normal Line Speed		High Line Speed		Layer		Total	
	lb	kN	ft/min	m/min	ft/min	m/min	ft	m	ft	m
1	25,955	115.5	131	39.9	262	79.9	125	38.1	125	38.1
2	23,418	104.2	145	44.2	291	88.7	138	42.0	263	80.2
3	21,332	94.9	159	48.8	319	97.2	152	46.3	415	126.5
4	19,588	87.1	174	53.0	348	106.0	165	50.3	588	179.2
5	18,108	80.5	188	57.3	376	114.6	179	54.6	759	231.3
6	16,835	74.9	202	61.5	405	123.4	192	58.5	951	289.9

Wire Rope Application		Diameter		Type	Maximum Permissible Load	
		in	mm		lb	kN
Main (Front) Winch	Standard	7/8	22	18x19 rotation resistant — right regular lay (Type RB)	17,520	77.9
	Optional	7/8	22	36x7 rotation resistant — right regular lay (Type ZB)	20,920	93.0
	Optional	7/8	22	34x7 rotation resistant — right regular lay (Type YB)	21,680	96.43
Auxiliary (Rear) Winch	Standard	7/8	22	18x19 rotation resistant — right regular lay (Type RB)	17,520	77.9
	Optional	7/8	22	36x7 rotation resistant — right regular lay (Type ZB)	20,920	93.0
	Optional	7/8	22	34x7 rotation resistant — right regular lay (Type YB)	21,680	96.43

2M Main (Front) and Optional Auxiliary (Rear) Winches

- Axial piston, full and half displacement (2—speed) motors driven through planetary reduction unit for positive control under all load conditions.
- Grooved lagging
- Power up/down mode of operation
- Hoist drum cable follower — optional
- Drum rotation indicator
- Drum diameter: 15 in (38.1cm)
- Rope length:
 - Main (Front): 900 ft (274.3m)
 - Auxiliary (Rear): 675 ft (205.7m) or 900 ft (274.3m)
- Maximum rope storage: 951 ft (289.9m)
- Terminator style socket and wedge

■ Hydraulic System

All functions are hydraulically powered allowing positive precise control with independent or simultaneous operation of all functions.

Main Pumps

- One, three section gear pump for the boom hoist, telescope, swing, and charge circuits.
- Two, closed-loop piston pumps are mounted to the rear of the pump drive. The front pump drives the front winch and the rear pump drives the optional rear winch.
- One, pressure compensated piston pump mounted to the rear of the rear winch pump supplies hydraulic power to the controls, counterweight handling, and hydraulically offsettable fly (optional) circuits.

Hydraulic Reservoir – 155 gal (586.7L) capacity equipped with sight level gauge. Diffusers built in for deaeration. Magnetic drain plug and large internal magnet.

Filtration

- One, 6-micron filter located inside hydraulic reservoir, accessible for easy replacement
- One, 6-micron charge filter located next to the reservoir with an in-cab indicator light
- One, magnetic suction strainer located inside the hydraulic reservoir

Valve Control “fine inching” Mode – Special fine metering valve settings, selectable from the operator’s cab, allows very slow movements to the main and auxiliary winches, boom hoist, and swing for precision work.

Counterbalance Valves – All boom extend cylinders and boom hoist cylinder are equipped with counterbalance valves to provide load lowering and prevents accidental load drop when hydraulic power is suddenly reduced.

Hydraulic Oil Cooler – Remote mounted, removes heat from the hydraulic oil.

Boom Hoist Float Valves – For transporting the boom over the rear of the crane with a boom dolly. Allows hydraulic oil within the boom hoist cylinder to flow between piston side and case side.

Swing Brake Release Valve – For transporting the boom over the rear of the crane with a boom dolly. Holds the 360° swing park brake in the released position allowing free rotation of the upperstructure.

■ Pump Drive

All pumps are mechanically driven by the diesel engine. Boom hoist and telescope pumps have an activation delay during engine start to aid in cold weather starting.

■ Fuel Tank

One 60 gal (227.1L) capacity tank

One 5 gal (18.9L) capacity diesel exhaust fluid (DEF) plastic tank

■ Engine

Specification	Cummins QSB – 6.7
Emissions Compliance Level:	Tier 4f/Stage IV ⁽¹⁾
Maximum allowable sulfur content of fuel (PPM):	15
Numbers of cylinders	6
Cycle	4
Bore and Stroke: inch (mm)	4.21 x 4.88 (107x124)
Piston Displacement: in ³ (L)	409 (6.7)
Max. Brake Horsepower: hp (kW)	250 (186) @ 2,000 rpm
Peak Torque: ft lb (Nm)	730 (990.0) @ 1,500 rpm
Alternator: volts – amps	12 – 160
Crankcase Capacity: qt (L)	18.4 (17.4)
<ul style="list-style-type: none"> • 120 V engine block heater • Water/fuel separator w/heater and water in fuel (WIF) sensor. <p>⁽¹⁾ Can only be sold and/or operated where Tier 4f/Stage IV off-highway emission standards are accepted.</p>	

■ Counterweight

Standard – Total of 20,000 lb (9t) consisting of auxiliary winch or 2,000 lb (0.9t) counterweight and four hydraulically removable counterweights. Assembled and disassembled by hydraulic cylinders controlled from the operator’s cab with capacities for:

- 0 lb (0t) counterweight
- 4,000 lb (1.8t) counterweight
- 8,000 lb (3.6t) counterweight
- 14,000 lb (6.3t) counterweight
- 20,000 lb (9t) counterweight

Optional – 12,000 lb (5.4t) in addition to standard counterweight for a total of 32,000 lb (14.5t) counterweight with additional capacities for:

- 32,000 lb (14.5t) counterweight

Optional – 25,000 lb (11.3t) in addition to standard counterweight for a total of 45,000 lb (20.4t) counterweight with additional capacities for:

- 32,000 lb (14.5t) counterweight
- 45,000 lb (20.4t) counterweight

Optional – 40,000 lb (18.1t) in addition to standard counterweight for a total of 60,000 lb (27.2t) with additional capacities for:

- 32,000 lb (14.5t) counterweight
- 45,000 lb (20.4t) counterweight
- 60,000 lb (27.2t) counterweight*

Low speed jobsite travel is offered for these optional counterweight configurations and a boom dolly or boom trailer may be required for on-highway travel.

* Overall width of the crane increases to 13 ft 8 in (4.2m) for this counterweight configuration.

20,000 lb (9t)

- A* 2,000 lb (0.9t) Top or Auxiliary Winch
- B 2,000 lb (0.9t) Top Tray
- C 4,000 lb (1.8t) Bottom Tray
- D 6,000 lb (2.7t) Piece
- D 6,000 lb (2.7t) Piece

32,000 lb (14.5t)

- A* 2,000 lb (0.9t) Top or Auxiliary Winch
- B 2,000 lb (0.9t) Top Tray
- E 12,000 lb (5.4t) Piece
- C 4,000 lb (1.8t) Bottom Tray
- D 6,000 lb (2.7t) Piece
- D 6,000 lb (2.7t) Piece

45,000 lb (20.4t)

- B 2,000 lb (0.9t) Top Tray
- A* 2,000 lb (0.9t) Top or Auxiliary Winch
- F 13,000 lb (5.9t) Piece
- E 12,000 lb (5.4t) Piece
- C 4,000 lb (1.8t) Bottom Tray
- D 6,000 lb (2.7t) Piece
- D 6,000 lb (2.7t) Piece

60,000 lb (27.2t)

- B 2,000 lb (0.9t) Top Tray
- A* 2,000 lb (0.9t) Top or Auxiliary Winch
- F 13,000 lb (5.9t) Piece
- G 7,500 lb (3.4t) Piece
- C 4,000 lb (1.8t) Bottom Tray
- E 12,000 lb (5.4t) Piece
- D 6,000 lb (2.7t) Piece
- D 6,000 lb (2.7t) Piece
- G 7,500 lb (3.4t) Piece

Counterweight Packages		20,000 lb (9t) – Standard									
		32,000 lb (14.5t) – Optional									
Counterweight Modules		45,000 lb (20.4t) – Optional									
		60,000 lb (27.2t) – Optional									
		A	B	C	D	D	E	F	G	G	
		2,000 lb (0.9t) Top*	2,000 lb (0.9t) Top Tray	4,000 lb (1.8t) Bottom Tray	6,000 lb (2.7t) Piece	6,000 lb (2.7t) Piece	12,000 lb (5.4t) Piece	13,000 lb (5.9t) Piece	7,500 lb (3.4t) Piece	7,500 lb (3.4t) Piece	
Counterweight Usage Configurations	0 lb (0t)										
	A,B	4,000 lb (1.8t)	X	X							
	A,B,C	8,000 lb (3.6t)	X	X	X						
	A,B,C,D	14,000 lb (6.3t)	X	X	X	X					
	A,B,C,D,D	20,000 lb (9t)	X	X	X	X	X				
	A,B,C,D,D,E	32,000 lb (14.5t)	X	X	X	X	X	X			
	A,B,C,D,D,E,F	45,000 lb (20.4t)	X	X	X	X	X	X	X		
	A,B,C,C,D,E,F,G,G	60,000 lb (27.2t)	X	X	X	X	X	X	X	X	

* Auxiliary winch replaces this counterweight for a two-drum configuration

Carrier

■ General

- 9 ft 10 in (3.0m) wide
- 28 ft 1 in (8.56m) wheelbase (centerline of first axle to centerline of fifth axle)
- **Frame** — Box-type, torsion resistant, welded construction made of high tensile steel. Equipped with front and rear towing and tie-down lugs, tow connections, and access ladders.

■ Outriggers

Boxes — Two double box, front and rear welded to the carrier frame

Beams and Jacks — Four dual stage beams with Confined Area Lifting Capacities (CALC) provide selectable outrigger extensions of full, intermediate, and retracted positions. Jacks with integral check valves, hydraulically controlled from the operator's cab and on both sides of carrier. A fifth front bumper outrigger with integral check valves is hydraulically controlled from the operator's cab, left & right O/R keypads and at the front bumper of carrier and includes a horn pressure switch for overload signaling.

Pontoons

- **Main** — Four lightweight, stow'n go, 26" (66cm) diameter steel pontoons with a contact area of 531 in² (3 425cm²) can be stored for road travel in either the storage racks on the carrier or under the outrigger boxes
- **Front Bumper** — One, lightweight, self-storing, 16" (40.6cm) diameter steel pontoon with a contact area of 201 in² (1 296cm²)

Jack Reaction

- **Main** — 160,000 lb (711.7kN) force and 301 psi (2 075kPa) ground bearing pressure
- **Front Bumper** — 66,000 lb (293.6kN) force and 303 psi (2 089kPa) ground bearing pressure

■ Steering and Axles

- Full integral master gear/slave gear steering system provides hydraulic assisted steering with mechanical link between steering wheel and wheels
- **Drive** — 10 x 6 for on/off-highway travel
- **Axle 1 & 2** — Tandem steered, non-driven
- **Axle 3, 4, & 5** — Tridem non-steered, driven
- **Inter-Axle Differential Lock** — Traction adding device that locks axle 3 with axle 4 and axle 4 with axle 5. Operated by a switch from the carrier cab.
- **Transaxle (Cross-axle) Differential Lock** — Traction adding device that locks differentials within axles 3, 4, and 5. Operated by a switch from the carrier cab.

■ Suspension

Hydro-pneumatic with automatic ride height leveling, independent front, rear, left & right adjustment, automatic cylinder locking that allows cylinder extension & retraction while raised on jacks and longitudinal and transverse trailing arms at all axles. The carrier suspension cylinders can be extended and retracted from controls in the carrier cab shifter console, from buttons in the carrier cab display and from left & right O/R keypads.

- Cylinder stroke: -3.5 in (-88.9mm) / +3.5 in (88.9mm)

■ Ground Control Outrigger/Suspension Controls

Environmentally sealed and ergonomically positioned, control stations located on both sides of the carrier with controls for crane operations including:

- Starts and stops carrier engine
- Throttles carrier engine up and down
- Suspension operation including:
 - Retract suspension (raise suspension) on outriggers
 - Retract suspension (Lower the carrier) on tires
- Outrigger operation including:
 - Extends and retracts two beams together
 - Extends and retracts all jacks together
 - Extend and retract fifth (bumper) outrigger
 - Automatic leveling on outriggers
- Outrigger lighting
- Bubble level

■ Tires and Wheels

Front — Four (single) 445/65R22.5 tires on aluminum disc wheels

Rear — Twelve (dual) 12R24.5 tires on aluminum disc wheels

- Spare tires and wheels — optional
- Tire inflation kit — optional

■ Brakes

Service — Full air anti-lock (ABS) brakes on all wheel ends. Dual circuit compressed air system with air dryer.

Parking/Emergency — Spring loaded type, acting on 3rd, 4th, and 5th axles automatically apply when air pressure drops below 40 psi (275.8kPa) in both circuits.

Hill Start Aid (HSA) — Prevents roll-back or roll-forward while launching on grades.

■ Central Lubrication System

Automated lubrication unit that injects grease into the steering gear arms, steering knuckles, axle king pins, and suspension cylinders. Activated by a timer on the lubrication unit.

■ Electrical

Battery — Three batteries provide 12 volt starting and operation

Lights

- Front lighting includes two main daytime running/headlights, two high beam lights, two parking/directional indicators, and three cab marker lights.
- Side lighting includes three parking/directional indicators per side.
- Rear lighting includes two parking/directional indicators, two parking/brake lights, two reverse lights, three marker lights, and a license plate light.
- Other equipment includes hazard/warning system, cab lights, instrument panel lights, fuel filler light, storage box light, and rear step lights.
- One amber strobe beacon behind the cab
- Outrigger working lights

■ Engine

Specification	Cummins ISX 15
Emission compliance level:	EPA2013 ⁽¹⁾
Maximum allowable sulfur content of fuel (PPM):	15
Numbers of cylinders	6
Cycle	4
Bore and Stroke: inch (mm)	5.39 x 6.65 (137x169)
Piston Displacement: in ³ (L)	912 (14.9)
Max. Brake Horsepower: hp (kW)	581 (434) @ 2,000 rpm 550 (410.0) @ 1,800 rpm
Peak Torque: ft lb (Nm)	1,850 (2 508) @ 1,200 rpm
Alternator: volts – amps	12 – 160
Crankcase Capacity: qt (L)	52 (49.2)
<ul style="list-style-type: none"> • Cruise control • Three-stage engine compression brake • Engine driven variable speed fan • Thermostatically controlled radiator • 120 V engine block heater • Ether injection system – optional 	
⁽¹⁾ Can only be sold and/or operated where EPA2013 on–highway emission standards are accepted.	

■ Transmission

Main Transmission – Automated – Eaton Ultra Shift[□] Plus w/Hill Start Aid (HSA) (no clutch pedal) transmission with 11 forward gears and 3 reverse gears.

Auxiliary Transmission – Air actuated manual transmission with two gears.

■ Carrier Speeds and Gradeability

Eaton Ultra Shift [□] Plus		Speed				Gradeability (@ peak torque Except Creep @ Idle)	
Gear	Ratio	(1.00)		(2.04)		% Grade	
		mph	km/h	mph	km/h	Min.	Max.
11th	0.73	65.62	105.61	32.16	51.76	1.69	3.45
10th	1.00	47.90	77.09	23.48	37.79	2.90	5.67
9th	1.38	34.71	55.86	17.01	27.37	4.46	8.71
8th	1.95	24.56	39.53	12.04	19.38	6.71	13.21
7th	2.77	17.29	27.83	8.48	13.65	9.88	19.64
6th	3.79	12.64	20.34	6.20	9.98	13.80	27.61
5th	5.23	9.16	14.74	4.49	7.23	19.31	38.84
4th	7.41	6.46	10.40	3.17	5.10	23.17	46.69
3rd	11.85	4.04	6.50	1.98	3.19	28.96	58.49
2nd	16.30	2.94	4.73	1.44	2.32	30.92	62.50
1st	26.08	1.84	2.96	0.90	1.45	38.66	78.28
Reverse (1)	20.84	2.30	3.70	1.13	1.82	33.30	67.36
Reverse (2)	13.03	3.68	5.92	1.80	2.90	20.59	41.42
Reverse (3)	3.43	13.96	22.47	6.29	10.12	6.50	14.02
1st @ Idle	26.08	0.60	0.97	0.32	0.51		
2nd @ Idle	16.30	0.96	1.54	0.50	0.80		
3rd @ Idle	11.85	1.31	2.11	0.69	1.11		
Reverse (1) @ Idle	20.84	0.75	1.21	0.39	0.63		
Reverse (2) @ Idle	13.03	1.19	1.92	0.63	1.01		

Based on a gross vehicle weight of 118,500 lbs (53 750.7kg)

■ Fuel Tank

- One 95 gal (359.6L) capacity tank
- One 10 gal (37.8L) capacity diesel exhaust fluid (DEF) plastic tank

■ Hydraulic System

All functions are hydraulically powered allowing positive, precise control with independent or simultaneous operation of all functions.

Main Pumps

- One fixed displacement gear pump for the steering circuit
- One fixed displacement gear pump for suspension and outriggers
- Combined pump capacity of 41 gpm (155.2Lpm)

Hydraulic Reservoir – 35 gal (132.5L) capacity equipped with sight level gauge. Diffusers built in for deaeration.

Filtration – Two 10 micron, full flow, return line filters. All oil is filtered prior to return to reservoir. Accessible for easy filter replacement.

■ Pump Drive

All pumps are mechanically driven by the diesel engine. Suspension and outriggers pump is direct mounted to the PTO at the bottom of the transmission. Steering pump is direct mounted to the engine.

■ Lower Cab and Controls

Environmental Cab — Fully enclosed, one person cab of composite structure with acoustical insulation. Equipped with:

- Tinted and tempered glass windows
- Roll down left side window for ventilation
- Right side window
- Adjustable sun visor
- Intermittent windshield wiper and washer
- Two remote control, heated, side view mirrors
- 3 LED Dome lights
- Six way adjustable and air suspended driver's seat with seat belt
- Fire extinguisher
- 2 Coat hooks
- Document storage unit

Air Conditioning — A/C with integral Engine dependent warm-water heater and fresh air intake or air recirculation with air ducts for windshield defroster and cab floor.

Overhead console — Located above the sun visor

- Document storage unit
- AM/FM Radio
- 2 — 12 volt accessory outlet (switched & unswitched)
- Strobe/Beacon switch (optional)

Camera Display — Located on dash console

- Displays right side of machine
- Displays rear view

Cab Instrumentation — Ergonomically positioned instrumentation for driving including:

- Speedometer with odometer, hour meter, trip meter, and clock
- Tachometer
- Front and rear system air pressure with warning indicator
- Diesel emissions fluid level with warning indicator

Dash Mounted LCD Display — Ergonomically positioned on the right of driver's front dash panel, digital instrumentation and indicators for crane operations including:

Gauges

- Engine water temperature
- Engine oil pressure
- Fuel level
- Voltmeter

Indicator Lights

- Check engine
- Stop engine
- Malfunction indicator lamp⁽¹⁾
- Diesel Exhaust Fluid (DEF) low level⁽¹⁾
- High exhaust temperature
- Exhaust regeneration
- Regeneration inhibit
- Air Filter restriction
- Park brake
- Swing brake
- Anti-lock Brake System (ABS)
- Trailer ABS
- Transaxle (cross-axle) differential lock
- Inter-axle differential lock
- Travel mode
- Ride height
- Cruise
- Seat belt
- 2-Speed Aux Transmission
- Traction control
- Hill start aid (HSA)
- PTO

Diagnostic Screens

- Engine
- Aftertreatment
- Suspension/Outriggers
- Telematics Mode

Dash Mounted Indicators For:

- Turn signal indication
- High beam headlights

Dash Panel — Controls and indicators for:

- Travel mode switch
- Carrier lights
- Dash panel dimmer switch
- Diesel particulate filter (DPF) inhibit switch
- DPF Regeneration switch
- PTO switch
- Remote mirror control switches
- Mirror heating switch
- Cab heater/air conditioning switch
- Cab heater/air conditioning fan switch
- Fresh air or recirculation switch
- Temperature control knob
- Carrier engine ignition switch

⁽¹⁾ (EPA 2013 engine only)

Right Side Dash Panel – Controls and indicators for:

- Park brake air valve
- Trailer brake air valve
- Inter-axle differential lock switch
- Transaxle (cross-axle) differential lock switch
- Traction control switch
- Transmission digital display
- Fan override switch

Right Side Shifter Console – Controls and indicators for:

- Transmission gear shifting
- Front axles (axles 1 & 2) suspension height switch
- Rear axles (axles 3–5) suspension height switch
- Ride height switch
- Engine compression brake controls
- Cruise controls
- Auxiliary transmission range selector switch
- Shifter console dimmer switch

Steering Column Controls For:

- Turn signal switch
- High beam switch
- Steering wheel adjustments
- Warning horn
- Hazard light switch
- Intermittent windshield wiper and washer

Foot Controls For:

- Carrier service brakes
- Engine throttle

Engine & Transmission Diagnostic – Located under the dash contains:

- Engine/Transmission diagnostic

Fuse & Diagnostic Center – Located inside cab behind seat contains:

- Fuses, Relays
- Control Modules

Diagnostic Center:

- ABS Diagnostic
- Suspension Diagnostic
- Cab display diagnostic

■ Additional Equipment

Standard:

- Aluminum full deck fenders with mud flaps
- Tow right side aluminum storage boxes
- Air hose connection ports
- Clearance flags

Optional:

- Pneumatic and electrical quick disconnect connectors mounted on the rear for trailer or boom dolly brakes and lights
- Rear mounted pintle hook

Axle Loads

Base crane with full tank of fuel and 2,000 lb (0.9t) counterweight	Gross Vehicle Weight (¹)		Front Axles		Rear Axles	
	lb	kg	lb	kg	lb	kg
	109,904	49 852	43,216	19 603	66,689	30 250
Driver in carrier cab	250	113	311	141	-61	-28
Rear pintle hook	44	20	-23	-10	67	30
Pneumatic and electrical connectors for trailer or boom dolly	15	7	1	-1	13	6
Ether injection	6	3	9	4	-2	1
Remove 2,000 lb (0.9t) of ctwt — for one winch configuration only	-2,039	-925	1,054	478	-3,093	-1 403
Hoist drum follower — main	101	46	-43	-19	144	65
Auxiliary winch with 675 ft (205.7m) of 7/8" (22mm) wire rope	1,213	550	-575	-261	1,789	812
Remove auxiliary winch with 675 ft (205.7m) of 7/8" (22mm) wire rope — for two winch configuration only	-3,019	-1 369	1,546	701	-4,565	-2 071
Hoist drum follower — auxiliary	101	46	-57	-26	158	72
Substitute 675 ft (205.7m) of rope with 900 ft (274.3m) of rope — auxiliary	378	171	-173	-78	551	250
Remove 900 ft (274.3m) of rope from front (main) winch	-1,535	-696	509	231	-2,044	-927
Remove 675 ft (205.7m) of rope from rear (auxiliary) winch	-1,157	-525	529	240	-1,686	-765
360° mechanical swing lock	140	66	23	10	117	53
4,000 lb (1.8t) counterweight bottom tray on carrier	4,000	1 814	-1,733	-786	5,733	2 600
6,000 lb (2.7t) counterweight on carrier	6,000	2 722	-2,599	-1 179	8,599	3 900
6,000 lb (2.7t) counterweight on carrier	6,000	2 722	-2,599	-1 179	8,599	3 900
12,000 lb (5.4t) counterweight on carrier	12,000	5 443	-5,198	-2 358	17,198	7 801
13,000 lb (5.9t) counterweight on carrier	13,000	5 897	-5,632	-2 555	18,632	8 451
2,000 lb (0.9t) counterweight top tray on upper	2,000	907	-806	-366	2,806	1 273
6,000 lb (2.7t) counterweight on rear carrier	6,000	2 722	-2,617	-1 187	8,617	3 909
Floodlight to the front of boom base section	7	3	11	5	-4	-2
Fly mounting brackets to boom base section for fly options	290	132	309	140	-19	-9
31—55 ft (9.45—16.76m) offsettable, two—piece (bi—fold) lattice fly — stowed	2,734	1 240	2,820	1 279	-86	-39
10—31—55 ft (3.05—9.45—16.76m) offsettable, three—piece (bi—fold) lattice fly — stowed	3,331	1 511	3,684	1 671	-353	-160
10—31—55 ft (3.05—9.45—16.76m) hydraulically offsettable, three—piece (bi—fold) lattice fly — stowed	3,804	1 725	4,460	2 023	-656	-298
Additional components for hydraulically offsettable fly	469	213	607	275	-138	-63
Auxiliary lifting sheave	120	54	223	116	-103	-61
35 ton (31.8mt) 1—sheave hook block at front bumper	1,100	499	1,795	814	-695	-315
50 ton (45.4mt) 4—sheave hook block at front bumper	1,200	544	1,958	888	-758	-344
80 ton (72.6mt) 5—sheave hook block at front bumper	1,411	640	2,302	1 044	-891	-404
100 ton (90.7mt) 6—sheave hook block at front bumper	1,750	794	2,855	1 295	-1,105	-501
140 ton (127.0mt) 7—sheave hook block at front bumper	2,394	1 086	3,906	1 772	-1,512	-686
12 ton (10.9mt) hook ball at front bumper	722	327	1,178	534	-456	-207

Counterweight Load Transfer	Front Axles		Rear Axles	
	lb	kg	lb	kg
Transfer 4,000 lb (1.8t) counterweight tray to carrier deck	4,664	2 116	-4,664	-2 116
Transfer 6,000 lb (2.7t) counterweight to carrier deck	6,996	3 173	-6,996	-3 173
Transfer 6,000 lb (2.7t) counterweight to carrier deck	6,996	3 173	-6,996	-3 173
Transfer 12,000 lb (5.4t) counterweight to carrier deck	13,992	6 347	-13,992	-6 347
Transfer 13,000 lb (5.9t) counterweight to carrier deck	15,158	6 876	-15,158	-6 876

Axle	Maximum Load @ 65 mph (105km/h)
Front	49,200 lb (22 317kg) — aluminum disc wheels with 445/65R22.5 tires
Rear	74,184 lb (33 650kg) — aluminum disc wheels with 12R24.5 tires

(¹) Adjust gross vehicle weight and axle loading according to component weight. All weights are ±3%.

Axle Loads with 2–Axle or 3–Axle Boom Dolly

Base crane with full tank of fuel and 2,000 lb (0.9t) counterweight	Gross Vehicle Weight ⁽¹⁾		Front Axles		Rear Axles		Dolly Axles	
	lb	kg	lb	kg	lb	kg	lb	kg
	109,904	49 852	38,062	17 265	51,062	23 161	20,780	9 426
Nelson 2–axle boom dolly ⁽²⁾	6,000	2 722	0	0	0	0	6,000	2 722
Nelson 3–axle boom dolly ⁽²⁾	9,000	4 082	0	0	0	0	9,000	4 082
Driver in carrier cab	250	113	311	141	-61	-28	0	0
Rear pintle hook	44	20	-23	-10	67	30	0	0
Pneumatic and electrical connectors for trailer or boom dolly	15	7	1	-1	13	6	0	0
Ether injection	6	3	9	4	-2	1	0	0
Remove 2,000 lb (0.9t) of ctwt – for one winch configuration only	-2,038	-924	-1,664	-755	-374	-170	0	0
Hoist drum follower – main	101	46	73	33	28	13	0	0
Auxiliary winch with 675 ft (205.7m) of 7/8" (22mm) wire rope	1,213	550	939	426	274	124	0	0
Remove auxiliary winch with 675 ft (205.7m) of 7/8" (22mm) wire rope – for two winch configuration only	-3,019	-1 369	-2,450	-1 111	-569	-258	0	0
Hoist drum follower – auxiliary	101	46	87	40	14	6	0	0
Substitute 675 ft (205.7m) of rope with 900 ft (274.3m) of rope – auxiliary	378	171	286	130	92	42	0	0
Remove 900 ft (274.3m) of rope from front (main) winch	-1,535	-696	-969	-440	-566	-257	0	0
Remove 675 ft (205.7m) of rope from rear (auxiliary) winch	-1,157	-525	-876	-397	-281	-127	0	0
360° mechanical swing lock	140	64	19	9	121	55	0	0
4,000 lb (1.8t) counterweight bottom tray on carrier	4,000	1 814	2,931	1 330	1,069	485	0	0
6,000 lb (2.7t) counterweight on carrier	6,000	2 722	4,397	1 994	1,603	727	0	0
6,000 lb (2.7t) counterweight on carrier	6,000	2 722	4,397	1 994	1,603	727	0	0
12,000 lb (5.4t) counterweight on carrier	12,000	5 443	8,794	3 989	3,206	1 454	0	0
13,000 lb (5.9t) counterweight on carrier	13,000	5 897	9,526	4 321	3,474	1 576	0	0
2,000 lb (0.9t) counterweight top tray on upper	2,000	907	1,405	637	595	270	0	0
6,000 lb (2.7t) counterweight on rear carrier	6,000	2 722	-2,617	-1 187	8,617	3 909	0	0
Floodlight to the front of boom base section	7	3	-1	-1	-1	-1	8	4
Fly mounting brackets to boom base section for fly options	290	132	26	12	20	9	244	111
31–55 ft (9.45–16.76m) offsettable, two–piece (bi–fold) lattice fly – stowed	2,734	1 240	279	127	215	98	2,241	1 017
10–31–55 ft (3.05–9.45–16.76m) offsettable, three–piece (bi–fold) lattice fly – stowed	3,331	1 511	251	114	193	88	2,886	1 309
10–31–55 ft (3.05–9.45–16.76m) hydraulically offsettable, three–piece (bi–fold) lattice fly – stowed	3,804	1 725	197	89	151	68	3,456	1 568
Additional components for hydraulically offsettable fly	469	213	4	2	3	2	462	210
Auxiliary lifting sheave	120	54	-23	-10	-18	-8	161	73
35 ton (31.8mt) 1–sheave hook block at boom head	1,100	499	-185	-84	-142	-64	1,427	647
50 ton (45.4mt) 4–sheave hook block at boom head	1,200	544	-201	-91	-155	-70	1,556	706
80 ton (72.6mt) 5–sheave hook block at boom head	1,411	640	-237	-108	-182	-83	1,830	830
100 ton (90.7mt) 6–sheave hook block at boom head	1,750	794	-294	-133	-226	-103	2,270	1 030
140 ton (127.0mt) 7–sheave hook block at boom head	2,394	1 086	-402	-182	-309	-140	3,105	1 408
12 ton (10.9mt) hook ball at boom head	722	327	-121	-55	-93	-42	936	425

Counterweight Load Transfer	Front Axles		Rear Axles		Dolly Axles	
	lb	kg	lb	kg	lb	kg
Transfer 4,000 lb (1.8t) counterweight tray to boom dolly	-2,931	-1 330	-1,069	-485	4,000	1 814
Transfer 6,000 lb (2.7t) counterweight to boom dolly	-4,397	-1 994	-1,603	727	6,000	2 722
Transfer 6,000 lb (2.7t) counterweight to boom dolly	-4,397	-1 994	-1,603	727	6,000	2 722
Transfer 12,000 lb (5.4t) counterweight to boom dolly	-8,794	-3 989	-3,206	-1 454	12,000	5 443
Transfer 13,000 lb (5.9t) counterweight to boom dolly	-9,526	-4 321	-3,474	-1 576	13,000	5 897
Transfer 2,000 lb (0.9t) counterweight top tray to boom dolly	-1,405	-637	-595	-270	2,000	907

Axle	Maximum Load @ 65 mph (105km/h)
Front	49,200 lb (22 317kg) – aluminum disc wheels with 445/65R22.5 tires
Rear	74,184 lb (33 650kg) – aluminum disc wheels with 12R24.5 tires

⁽¹⁾ Adjust gross vehicle weight and axle loading according to component weight. All weights are $\pm 3\%$.

⁽²⁾ Weights may vary.

General Dimensions

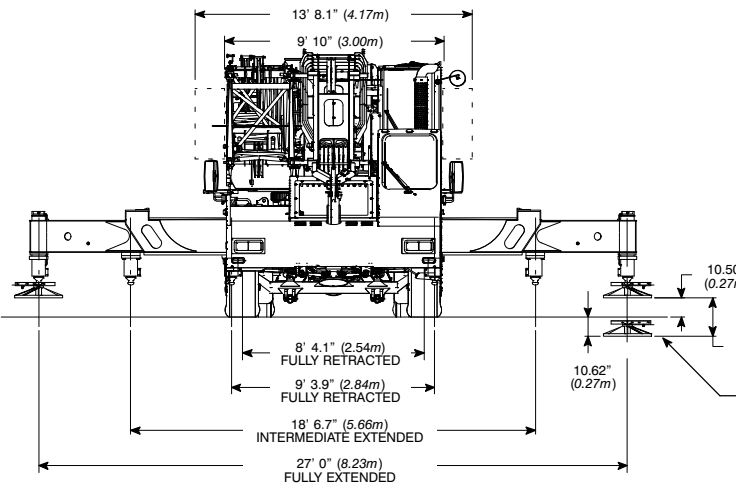
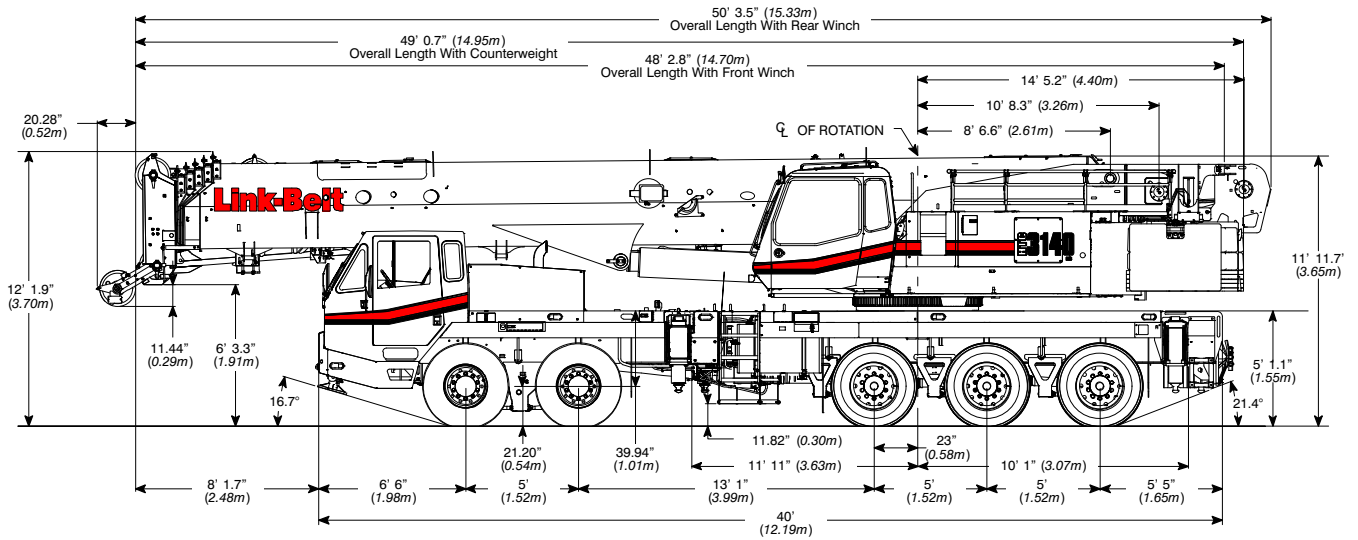

Turning Radius	English	Metric
Wall to wall over carrier	45' 4.2"	13.82m
Wall to wall over boom	49' 4"	15.04m
Wall to wall over boom attachment	50' 6.3"	15.40m
Curb to curb	41' 7.4"	12.68m
Centerline of tire	40' 9.9"	12.44m

Tail Swing	English	Metric
With two winches	15' 8.6"	4.79m
With counterweight	14' 11.13"	4.55m
Without counterweight	13' 8.3"	4.17m

Overall Width	English	Metric
With up to 45,000 lb (20.4t) counterweight	9' 10"	3.00m
With 60,000 lb (27.2t) counterweight	13' 8.1"	4.17m

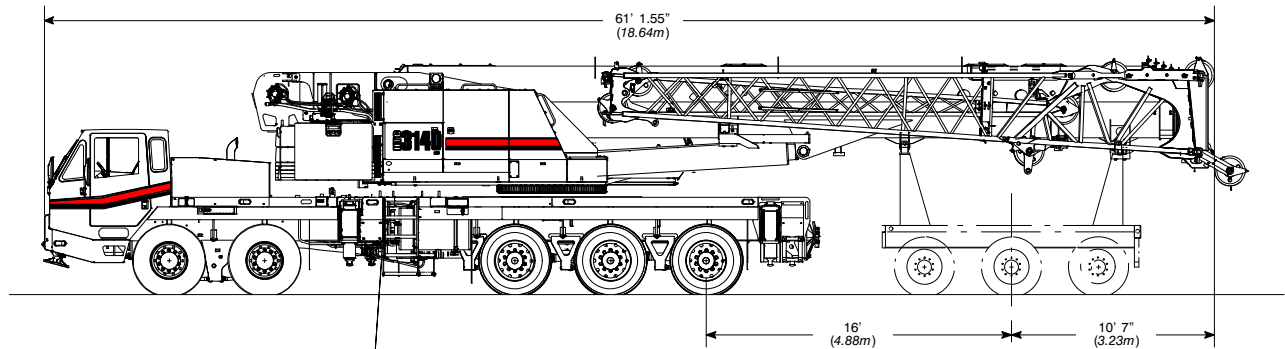

Not To Scale

Working Range Diagram

Height Above Ground — Feet (Meters)

Boom + Fly Length — Feet (Meters)

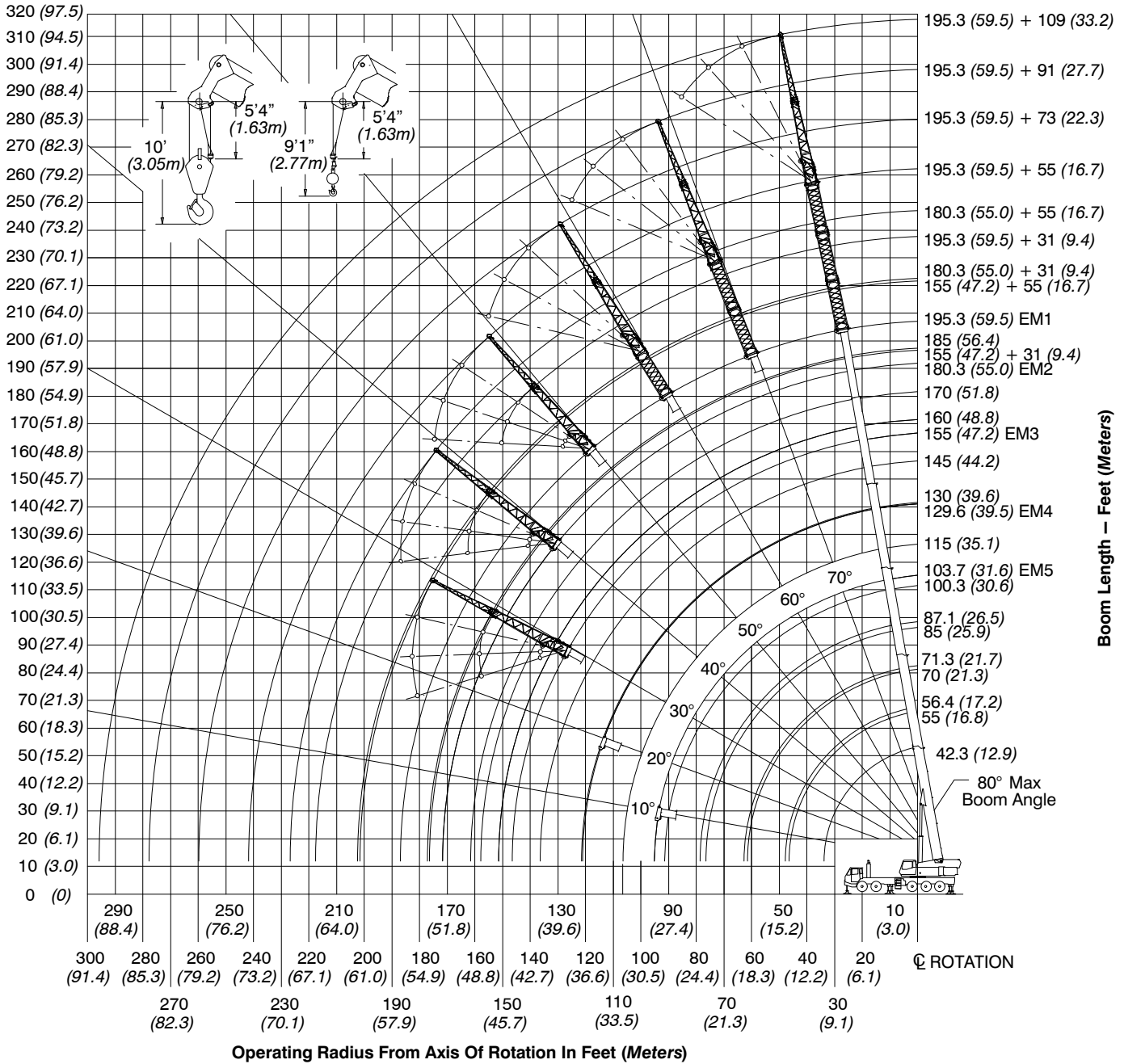

Boom Extend Modes

Boom Length		Telescope Length				
ft	m	T5	T4	T3	T2	T1
42.3	12.9					
55	16.8	44%				
70	21.3	96%				
85	25.9	100%	46%			
100	30.5	100%	97%			
115	35.1	100%	100%	46%		
130	39.6	100%	100%	95%		
145	44.2	100%	100%	100%	43%	
160	48.8	100%	100%	100%	90%	
175	53.3	100%	100%	100%	100%	37%
185	56.4	100%	100%	100%	100%	68%
195.3	59.5	100%	100%	100%	100%	100%

Boom Length		Telescope Length				
ft	m	T5	T4	T3	T2	T1
42.3	12.9					
55	16.8	90%	6%			
70	21.3	90%	57%			
85	25.9	90%	90%	17%		
100	30.5	90%	90%	66%		
115	35.1	90%	90%	90%	24%	
130	39.6	90%	90%	90%	71%	
145	44.2	90%	90%	90%	90%	28%
160	48.8	90%	90%	90%	90%	59%
170	51.8	90%	90%	90%	90%	91%
180.3	55.0	90%	90%	90%	90%	

Boom Length		Telescope Length				
ft	m	T5	T4	T3	T2	T1
42.3	12.9					
55	16.8	44%				
70	21.3	46%	47%	1%		
85	25.9	46%	47%	50%		
100	30.5	46%	47%	90%	9%	
115	35.1	46%	47%	90%	457%	
130	39.6	46%	47%	90%	90%	13%
145	44.2	46%	47%	90%	90%	60%
155	47.2	46%	47%	90%	90%	91%

Boom Length		Telescope Length				
ft	m	T5	T4	T3	T2	T1
42.3	12.9					
55	16.8	44%				
70	21.3	46%	47%	1%		
85	25.9	46%	47%	49%	2%	
100	30.5	46%	47%	49%	49%	
115	35.1	46%	47%	49%	50%	46%
129.6	39.5	46%	47%	49%	50%	91%

Boom Length		Telescope Length				
ft	m	T5	T4	T3	T2	T1
42.3	12.9					
56.4	17.2	0%	47%			
71.3	21.7	0%	47%	49%		
87.1	26.5	0%	47%	49%	50%	
103.7	31.6	0%	47%	49%	50%	51%

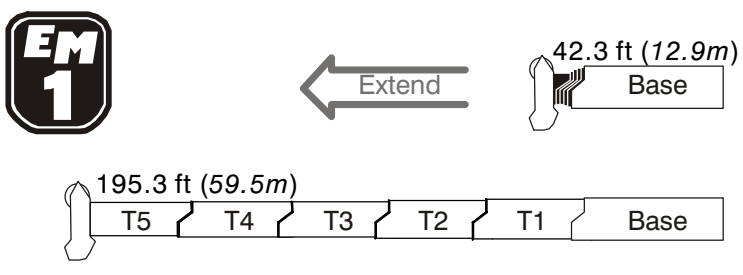

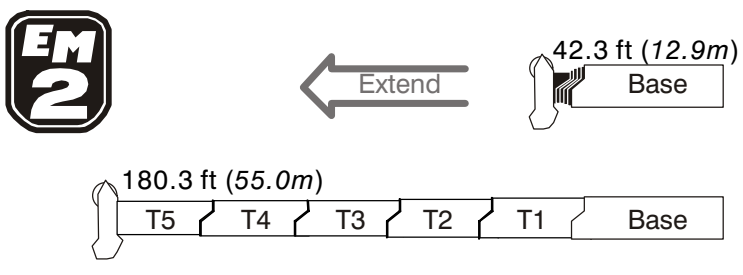

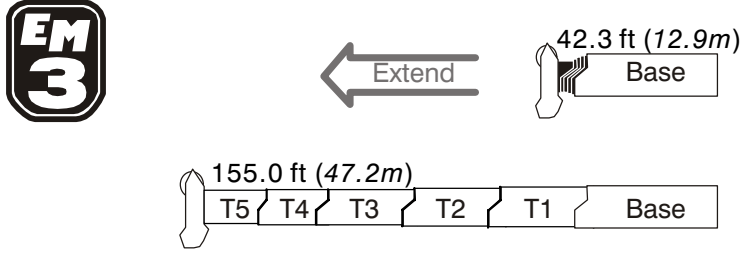

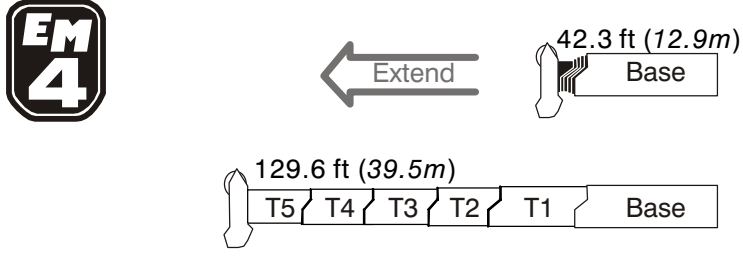

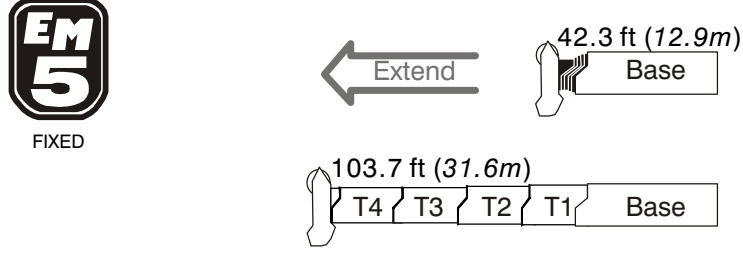

Main Boom Lift Capacity Charts – Standard

20,000 lb Counterweight – Fully Extended Outriggers – 360° Rotation (All Capacities Are Listed In Pounds)													
Radius (ft)	Main Boom Length (ft)											Radius (ft)	
	42.3	55	70	85	100	115	130	145	160	175	185		195.3
9	280,000*												9
10	264,900*	157,100	151,700										10
12	222,700*	157,100	144,800										12
15	177,800	157,100	137,400	110,100									15
20	131,100	134,600	118,300	106,500	80,700	61,300							20
25	102,200	105,700	103,700	93,500	77,100	61,300	49,400						25
30	78,200	83,300	84,600	83,200	67,900	61,300	47,400	41,000	35,500				30
35		63,100	65,500	65,900	65,000	61,300	45,500	41,000	35,500	28,000	18,800		35
40		49,400	51,900	52,100	51,500	50,200	40,800	40,300	35,500	28,000	18,800	17,000	40
45		39,600	43,100	42,500	41,900	40,500	36,800	36,800	33,000	28,000	18,800	17,000	45
50			35,700	36,500	35,200	34,400	32,500	33,200	30,000	28,000	18,800	17,000	50
55			30,100	31,300	30,700	29,200	28,600	27,700	27,200	27,900	18,800	17,000	55
60			25,600	26,900	27,200	26,500	25,900	25,000	24,800	24,800	18,800	17,000	60
65				23,200	24,000	23,800	23,100	23,200	21,800	21,200	18,800	17,000	65
70				20,200	21,000	20,900	20,500	20,200	19,700	18,900	18,400	17,000	70
75				17,700	18,500	18,400	18,300	17,700	17,300	16,700	16,200	15,800	75
80					16,400	16,500	16,400	15,900	15,400	14,600	14,200	13,700	80
85					14,600	14,600	14,600	14,100	13,600	12,900	12,400	11,900	85
90					13,000	13,000	13,000	12,500	12,000	11,300	10,800	10,400	90
95						11,600	11,600	11,100	10,700	10,000	9,500	9,000	95
100						10,400	10,300	9,900	9,500	8,800	8,300	7,900	100
105						9,300	9,200	8,800	8,400	7,700	7,200	6,800	105
110							8,200	7,800	7,400	6,700	6,300	5,800	110
115							7,400	6,900	6,600	5,900	5,400	5,000	115
120							6,600	6,100	5,800	5,100	4,600	4,200	120
125								5,400	5,000	4,400	3,900	3,500	125
130								4,700	4,400	3,700	3,300	2,900	130
135								4,200	3,700	3,100	2,700	2,300	135
140									3,200	2,500	2,100	1,700	140
145									2,700	2,000	1,600	1,200	145
150									2,200	1,600			150

* Special Conditions Or Wire Rope Required

This information is not for crane operation. Operator must refer to the in-cab information for crane operation. Rated lifting capacities shown on fully extended outriggers do not exceed 85% of the tipping loads and on tires do not exceed 75% of the tipping loads.

Main Boom Lift Capacity Charts – Optional

60,000 lb Counterweight – Fully Extended Outriggers – 360° Rotation (All Capacities Are Listed In Pounds)													
Radius (ft)	Main Boom Length (ft)											Radius (ft)	
	42.3	55	70	85	100	115	130	145	160	175	185		195.3
9	280,000*												9
10	264,900*	157,100	151,700										10
12	240,000*	157,100	144,800										12
15	204,500	157,100	137,400	110,100									15
20	151,600	152,200	118,300	106,500	80,700	61,300							20
25	118,800	122,200	103,700	93,500	77,100	61,300	49,400						25
30	96,400	99,900	92,100	83,200	67,900	61,300	47,400	41,000	35,500				30
35		83,800	82,900	74,700	65,000	61,300	45,500	41,000	35,500	28,000	18,800		35
40		72,200	72,700	67,700	62,400	57,400	40,800	40,300	35,500	28,000	18,800	17,000	40
45		62,600	64,600	61,900	57,000	52,000	36,800	36,800	33,000	28,000	18,800	17,000	45
50			56,400	54,800	52,400	47,500	33,300	33,700	30,000	28,000	18,800	17,000	50
55			48,500	49,000	48,400	43,500	30,300	31,000	27,300	27,900	18,800	17,000	55
60			42,100	42,700	42,200	40,200	27,600	28,600	24,900	26,000	18,800	17,000	60
65				37,500	37,100	36,000	25,400	26,400	23,100	24,200	18,800	17,000	65
70				33,300	33,000	32,000	23,600	24,500	21,500	22,600	18,800	17,000	70
75				29,800	29,400	28,500	22,000	22,800	20,100	21,100	18,800	17,000	75
80					26,300	25,400	20,600	21,200	18,800	19,800	17,900	17,000	80
85					23,700	22,800	19,300	19,800	17,700	18,600	16,600	15,800	85
90					21,400	20,500	18,000	18,400	16,600	17,400	15,400	14,700	90
95						18,500	16,900	17,100	15,600	16,300	14,400	13,600	95
100						17,300	15,900	16,000	14,700	15,300	13,400	12,600	100
105						16,300	15,000	14,900	13,800	14,400	12,400	11,700	105
110							14,100	13,800	13,000	13,500	11,600	10,900	110
115							13,400	12,500	12,300	12,800	10,800	10,100	115
120							12,800	11,900	11,600	12,000	10,000	9,300	120
125								11,300	11,000	11,300	9,400	8,700	125
130								10,700	10,400	10,600	8,700	8,000	130
135								10,100	9,900	9,700	8,100	7,400	135
140									9,300	8,900	7,500	6,800	140
145									8,600	8,400	7,000	6,300	145
150									7,900	7,900	6,500	5,800	150
155										7,200	6,000	5,300	155
160										6,600	5,600	4,900	160
165										6,100	5,100	4,500	165
170											4,700	4,100	170
175											4,400	3,700	175
180												3,300	180
185												3,000	185

* Special Conditions Or Wire Rope Required

This information is not for crane operation. Operator must refer to the in-cab information for crane operation. Rated lifting capacities shown on fully extended outriggers do not exceed 85% of the tipping loads and on tires do not exceed 75% of the tipping loads.

Manual Offset Fly Attachment Lift Capacity Charts – Optional

20,000 lb Counterweight – Fully Extended Outriggers – 360° Rotation (All Capacities Are Listed In Pounds)																	
Main Boom + 10 ft Manual Offset Fly (2°, 15°, 30°, 45° Offsets)																	
Radius (ft)	Main Boom Length (ft)															Radius (ft)	
	42.3	55.0	70.0	85.0	100.0	115.0	130.0	145.0	155.0	160.0	170.0	175.0	180.3	185.0	195.3		
10	51,800	51,800															10
12	47,300	51,800	51,800														12
15	46,400	46,700	51,800	51,800													15
20	45,200	45,600	45,800	45,500	51100												20
25	44,500	44,800	45,000	44,800	43400	45,800	40,200										25
30	44,500	44,300	44,400	44,200	42900	41,900	40,200	36,100	28,600	24,100		15,300					30
35	44,500	44,200	44,000	43,800	41400	40,900	38,400	36,100	28,600	24,100	22,300	15,300	19,700	14,200	12,400		35
40	44,500	44,200	43,900	43,500	37600	37,100	34,900	36,000	28,600	24,100	22,300	15,300	19,700	14,200	12,400		40
45		42,200	43,300	43,200	34500	34,100	32,000	33,300	28,600	24,100	22,300	15,300	19,700	14,200	12,400		45
50		34,800	35,900	35,800	31900	31,300	29,400	30,800	28,400	24,100	22,300	15,300	19,700	14,200	12,400		50
55		29,300	30,300	30,200	29500	28,800	27,000	27,700	25,800	24,100	22,300	15,300	19,700	14,200	12,400		55
60			26,700	27,200	25600	25,000	24,300	23,300	22,800	22,700	22,300	15,300	19,700	14,200	12,400		60
65			23,100	23,600	23400	22,300	21,600	21,000	19,200	21,000	20,900	15,300	19,700	14,200	12,400		65
70			20,200	20,700	20700	20,700	20,000	19,600	16,600	18,600	18,000	15,300	17,400	14,200	12,400		70
75				18,200	18,500	18,200	17,500	17,400	14,200	16,800	15,800	15,300	15,300	14,200	12,400		75
80				16,200	16,500	16,300	16,100	15,500	12,100	15,000	13,700	14,200	13,200	13,700	12,400		80
85				14,300	14,700	14,500	14,200	13,700	10,400	13,200	11,900	12,400	11,400	11,900	11,500		85
90					13,100	12,900	12,700	12,100	8,800	11,600	10,400	10,900	9,900	10,400	9,900		90
95					11,700	11,500	11,300	10,700	7,500	10,200	9,000	9,500	8,500	9,000	8,600		95
100					10,500	10,300	10,100	9,500	6,300	9,000	7,800	8,300	7,300	7,800	7,400		100
105						9,200	9,000	8,400	5,200	7,900	6,700	7,200	6,300	6,700	6,300		105
110						8,200	8,000	7,500	4,300	7,000	5,800	6,200	5,300	5,800	5,300		110
115						7,300	7,100	6,600	3,400	6,100	4,900	5,400	4,400	4,900	4,500		115
120							6,300	5,800	2,700	5,300	4,100	4,600	3,700	4,100	3,700		120
125							5,600	5,100	2,000	4,600	3,400	3,900	3,000	3,400	3,000		125
130							5,000	4,400		3,900	2,800	3,200	2,300	2,800	2,300		130
135								3,800		3,300	2,200	2,600	1,700	2,200	1,700		135
140								3,200		2,800	1,600	2,100		1,600			140
145								2,800		2,300		1,600					145
150										1,800							150
155										1,400							155

This information is not for crane operation. Operator must refer to the in-cab information for crane operation. Rated lifting capacities shown on fully extended outriggers do not exceed 85% of the tipping loads and on tires do not exceed 75% of the tipping loads.

60,000 lb Counterweight – Fully Extended Outriggers – 360° Rotation (All Capacities Are Listed In Pounds)																
Main Boom + 10 ft Manual Offset Fly (2°, 15°, 30°, 45° Offsets)																
Radius (ft)	Main Boom Length (ft)															Radius (ft)
	42.3	55.0	70.0	85.0	100.0	115.0	130.0	145.0	155.0	160.0	170.0	175.0	180.3	185.0	195.3	
10	51,800	51,800														10
12	47,300	51,800	51,800													12
15	46,400	46,700	51,800	51,800												15
20	45,200	45,600	45,800	45,500	51,100											20
25	44,500	44,800	45,000	44,800	43,400	45,800	40,200									25
30	44,500	44,300	44,400	44,200	42,900	41,900	40,200	36,100	28,600	24,100		15,300				30
35	44,500	44,200	44,000	43,800	41,400	40,900	38,400	36,100	28,600	24,100	22,300	15,300	19,700	14,200	12,400	35
40	44,500	44,200	43,900	43,500	37,600	37,100	34,900	36,000	28,600	24,100	22,300	15,300	19,700	14,200	12,400	40
45		44,200	43,900	43,300	34,500	34,100	32,000	33,300	28,600	24,100	22,300	15,300	19,700	14,200	12,400	45
50		44,200	43,900	43,300	31,900	31,300	29,400	30,800	28,400	24,100	22,300	15,300	19,700	14,200	12,400	50
55		42,400	43,900	43,300	29,500	28,800	27,000	28,500	25,800	24,100	22,300	15,300	19,700	14,200	12,400	55
60			43,300	40,700	27,300	26,600	24,900	26,500	23,500	22,700	22,300	15,300	19,700	14,200	12,400	60
65			38,200	38,100	25,400	24,700	23,100	24,500	21,500	21,000	21,800	15,300	19,700	14,200	12,400	65
70			34,100	34,000	23,800	22,900	21,400	22,700	19,700	19,500	20,400	15,300	19,100	14,200	12,400	70
75				30,400	22,300	21,400	19,900	21,100	18,100	18,200	19,000	15,300	16,800	14,200	12,400	75
80				27,400	20,900	20,000	18,600	19,600	16,800	17,100	17,800	15,300	16,400	14,200	12,400	80
85				24,800	19,700	18,700	17,300	18,200	15,500	16,000	16,900	15,300	15,200	14,200	12,400	85
90					18,600	17,500	16,400	17,200	14,200	15,000	15,800	14,300	14,000	14,200	12,400	90
95					17,600	16,700	15,400	16,100	13,100	14,000	14,900	13,300	12,900	13,200	12,400	95
100					16,900	15,700	14,400	15,000	12,100	13,200	14,000	12,500	12,000	12,200	11,500	100
105						14,800	13,500	14,000	11,100	12,300	13,100	11,700	11,100	11,300	10,600	105
110						13,900	12,700	13,000	10,200	11,600	12,300	11,000	10,200	10,500	9,800	110
115						13,200	12,000	12,100	9,400	10,900	11,500	10,300	9,400	9,700	9,000	115
120							11,300	11,200	8,600	10,300	10,800	9,700	8,700	9,000	8,300	120
125							10,700	10,200	7,900	9,700	10,100	9,100	8,000	8,300	7,600	125
130							10,200	9,400	7,200	9,100	9,500	8,500	7,400	7,700	7,000	130
135								8,900	6,600	8,600	8,900	8,000	6,800	7,100	6,400	135
140								8,400	6,000	8,100	8,400	7,600	6,200	6,600	5,900	140
145								8,000	5,500	7,600	7,700	7,100	5,700	6,000	5,400	145
150									5,000	7,200	7,000	6,700	5,200	5,600	4,900	150
155									4,500	6,800	6,400	6,300	4,700	5,100	4,400	155
160										6,300	5,800	5,900	4,300	4,700	4,000	160
165											5,200	5,600	3,900	4,200	3,600	165
170											4,700	5,100	3,500	3,900	3,200	170
175													3,100	3,500	2,800	175
180														3,100	2,500	180
185															2,100	185
190															1,800	190

This information is not for crane operation. Operator must refer to the in-cab information for crane operation. Rated lifting capacities shown on fully extended outriggers do not exceed 85% of the tipping loads and on tires do not exceed 75% of the tipping loads.

20,000 lb Counterweight – Fully Extended Outriggers – 360° Rotation (All Capacities Are Listed In Pounds)									
155.0 ft Main Boom Length									
Radius (ft)	31 ft Manual Offset Fly				55 ft Manual Offset Fly				Radius (ft)
	2°	15°	30°	45°	2°	15°	30°	45°	
40	18,900								40
45	18,900	17,700			13,100				45
50	18,900	17,400			12,800				50
55	18,900	17,100	15,200		12,500				55
60	18,800	16,800	15,000	13,800	12,200	10,500			60
65	18,500	16,500	14,800	13,700	11,900	10,300			65
70	17,200	16,200	14,600	13,600	11,600	10,000	8,700		70
75	15,000	16,000	14,400	13,500	11,400	9,800	8,500		75
80	13,000	14,000	14,200	13,400	11,100	9,600	8,400	7,600	80
85	11,200	12,100	13,100	13,300	10,800	9,400	8,300	7,500	85
90	9,600	10,500	11,400	12,000	10,600	9,200	8,100	7,500	90
95	8,300	9,100	9,900	10,500	9,400	9,000	8,000	7,400	95
100	7,100	7,800	8,500	9,100	8,200	8,900	7,900	7,300	100
105	6,000	6,700	7,300	7,800	7,100	8,300	7,800	7,300	105
110	5,000	5,700	6,300	6,700	6,100	7,200	7,700	7,200	110
115	4,200	4,800	5,300	5,600	5,300	6,300	7,300	7,200	115
120	3,400	3,900	4,400	4,700	4,500	5,400	6,400	7,100	120
125	2,700	3,200	3,600	3,900	3,700	4,600	5,500	6,100	125
130	2,000	2,500	2,900	3,100	3,100	3,900	4,700	5,300	130
135	1,500	1,900	2,200	2,400	2,500	3,200	4,000	4,500	135
140		1,300	1,600	1,700	1,900	2,600	3,300	3,700	140
145					1,400	2,000	2,700	3,000	145
150						1,500	2,100	2,400	150
155							1,500	1,800	155
160								1,200	160

This information is not for crane operation. Operator must refer to the in-cab information for crane operation. Rated lifting capacities shown on fully extended outriggers do not exceed 85% of the tipping loads and on tires do not exceed 75% of the tipping loads.

60,000 lb Counterweight – Fully Extended Outriggers – 360° Rotation
(All Capacities Are Listed In Pounds)

155.0 ft Main Boom Length

Radius (ft)	31 ft Manual Offset Fly				55 ft Manual Offset Fly				Radius (ft)
	2°	15°	30°	45°	2°	15°	30°	45°	
40	18,900								40
45	18,900	17,700			13,100				45
50	18,900	17,400			12,800				50
55	18,900	17,100	15,200		12,500				55
60	18,800	16,800	15,000	13,800	12,200	10,500			60
65	18,500	16,500	14,800	13,700	11,900	10,300			65
70	18,100	16,200	14,600	13,600	11,600	10,000	8,700		70
75	17,300	16,000	14,400	13,500	11,400	9,800	8,500		75
80	16,000	15,700	14,200	13,400	11,100	9,600	8,400	7,600	80
85	14,800	15,200	14,100	13,300	10,800	9,400	8,300	7,500	85
90	13,700	14,100	13,900	13,200	10,600	9,200	8,100	7,500	90
95	12,700	13,100	13,400	13,200	10,300	9,000	8,000	7,400	95
100	11,700	12,100	12,500	12,800	10,100	8,900	7,900	7,300	100
105	10,900	11,200	11,600	11,800	9,800	8,700	7,800	7,300	105
110	10,100	10,400	10,700	11,000	9,600	8,500	7,700	7,200	110
115	9,300	9,600	9,900	10,200	9,200	8,400	7,600	7,200	115
120	8,600	8,900	9,200	9,400	8,500	8,200	7,500	7,200	120
125	8,000	8,200	8,500	8,700	7,900	8,100	7,500	7,100	125
130	7,400	7,600	7,900	8,000	7,300	7,700	7,400	7,100	130
135	6,800	7,000	7,200	7,400	6,700	7,100	7,300	7,000	135
140	6,200	6,500	6,700	6,800	6,200	6,600	7,000	7,000	140
145	5,700	5,900	6,100		5,700	6,100	6,400	6,700	145
150	5,300	5,500	5,600		5,300	5,600	5,900	6,100	150
155	4,800	5,000	5,100		4,900	5,200	5,500	5,600	155
160	4,400	4,600	4,700		4,400	4,700	5,000	5,100	160
165	4,000	4,200			4,100	4,300	4,600	4,700	165
170	3,700	3,800			3,700	3,900	4,100		170
175	3,400	3,400			3,400	3,600	3,800		175
180					3,000	3,200	3,400		180
185					2,800	2,900	3,000		185
190					2,500	2,600			190
195					2,300	2,300			195
200					2,100				200

This information is not for crane operation. Operator must refer to the in-cab information for crane operation. Rated lifting capacities shown on fully extended outriggers do not exceed 85% of the tipping loads and on tires do not exceed 75% of the tipping loads.

60,000 lb Counterweight – Fully Extended Outriggers – 360° Rotation (All Capacities Are Listed In Pounds)														
155.0 ft Main Boom Length														
Radius (ft)	73 ft Manual Offset Fly				91 ft Manual Offset Fly				109 ft Manual Offset Fly				Radius (ft)	
	2°	15°	30°	45°	2°	15°	30°	45°	2°	15°	30°	45°		
50	11,200													50
55	11,200				8,600									55
60	11,100				8,600					6,700				60
65	10,900	9,900			8,600					6,700				65
70	10,800	9,700			8,600	8,700				6,700				70
75	10,600	9,500	8,400		8,600	8,600				6,700	6,700			75
80	10,400	9,400	8,300		8,600	8,200	7,200			6,700	6,400			80
85	10,200	9,200	8,200		8,600	7,800	6,900			6,500	6,000			85
90	10,100	9,100	8,000	7,300	8,300	7,400	6,600			6,100	5,700	5,200		90
95	9,900	8,900	7,900	7,100	7,900	7,100	6,300	5,800		5,800	5,400	4,900		95
100	9,700	8,800	7,700	6,900	7,500	6,800	6,000	5,600		5,500	5,100	4,600	4,400	100
105	9,500	8,600	7,500	6,700	7,100	6,500	5,800	5,400		5,200	4,800	4,400	4,100	105
110	9,400	8,300	7,200	6,600	6,800	6,200	5,500	5,100		4,900	4,500	4,200	3,900	110
115	9,100	8,000	7,000	6,400	6,500	5,900	5,300	4,900		4,600	4,300	3,900	3,700	115
120	8,400	7,700	6,800	6,200	6,200	5,700	5,100	4,800		4,400	4,100	3,700	3,500	120
125	7,800	7,500	6,600	6,100	5,900	5,400	4,900	4,600		4,100	3,800	3,500	3,300	125
130	7,200	7,300	6,400	6,000	5,700	5,200	4,700	4,400		3,900	3,600	3,400	3,200	130
135	6,600	7,000	6,300	5,800	5,500	5,000	4,600	4,300		3,700	3,500	3,200	3,000	135
140	6,100	6,500	6,100	5,700	5,200	4,800	4,400	4,200		3,500	3,300	3,000	2,900	140
145	5,600	6,000	6,000	5,600	5,000	4,600	4,200	4,000		3,400	3,100	2,900	2,700	145
150	5,100	5,500	5,800	5,500	4,600	4,500	4,100	3,900		3,200	3,000	2,700	2,600	150
155	4,700	5,000	5,400	5,400	4,200	4,300	4,000	3,800		3,000	2,800	2,600	2,500	155
160	4,200	4,600	4,900	5,200	3,800	4,100	3,800	3,700		2,900	2,700	2,500	2,400	160
165	3,800	4,100	4,500	4,700	3,400	3,700	3,700	3,600		2,700	2,500	2,300	2,200	165
170	3,500	3,700	4,100	4,300	3,000	3,400	3,600	3,500		2,600	2,400	2,200	2,100	170
175	3,100	3,400	3,700	3,800	2,700	3,000	3,300	3,400		2,200	2,300	2,100	2,000	175
180	2,800	3,000	3,300	3,400	2,400	2,600	3,000	3,200		1,900	2,200	2,000	2,000	180
185	2,400	2,700	2,900		2,000	2,300	2,600	2,800		1,600	1,900	1,900	1,900	185
190	2,100	2,300	2,500		1,800	2,000	2,300	2,400		1,300	1,600	1,800	1,800	190
195	1,800	2,000	2,200		1,500	1,700	1,900	2,000			1,300	1,600	1,700	195
200	1,600	1,700	1,900		1,200	1,400	1,600					1,300	1,400	200
205	1,300	1,500	1,500				1,300							205
210		1,200												210

This information is not for crane operation. Operator must refer to the in-cab information for crane operation. Rated lifting capacities shown on fully extended outriggers do not exceed 85% of the tipping loads and on tires do not exceed 75% of the tipping loads.

20,000 lb Counterweight – Fully Extended Outriggers – 360° Rotation (All Capacities Are Listed In Pounds)									
195.3 ft Main Boom Length									
Radius (ft)	31 ft Manual Offset Fly				55 ft Manual Offset Fly				Radius (ft)
	2°	15°	30°	45°	2°	15°	30°	45°	
50	10,800								50
55	10,800				8,300				55
60	10,800	10,800			8,300				60
65	10,800	10,800			8,300				65
70	10,800	10,800	10,900		8,300				70
75	10,800	10,800	10,900	11,100	8,300	8,400			75
80	10,800	10,800	10,900	11,100	8,300	8,300			80
85	10,800	10,800	10,900	11,100	8,300	8,200			85
90	10,300	10,800	10,900	11,100	8,300	8,200	7,400		90
95	8,900	9,700	10,500	11,100	8,300	8,100	7,300		95
100	7,700	8,400	9,200	9,800	8,300	8,000	7,300	6,800	100
105	6,600	7,300	8,000	8,500	7,400	7,900	7,200	6,800	105
110	5,600	6,300	6,900	7,400	6,400	7,500	7,100	6,800	110
115	4,800	5,400	6,000	6,400	5,500	6,600	7,100	6,700	115
120	4,000	4,600	5,100	5,500	4,700	5,700	6,700	6,700	120
125	3,300	3,800	4,300	4,700	4,000	4,900	5,900	6,600	125
130	2,600	3,100	3,600	3,900	3,300	4,200	5,100	5,800	130
135	2,000	2,500	2,900	3,200	2,700	3,500	4,400	5,000	135
140	1,500	1,900	2,300	2,600	2,100	2,900	3,700	4,300	140
145		1,400	1,700	2,000	1,600	2,400	3,100	3,600	145
150			1,200	1,400		1,800	2,500	3,000	150
155						1,400	2,000	2,400	155
160							1,500	1,900	160
165								1,400	165

This information is not for crane operation. Operator must refer to the in-cab information for crane operation. Rated lifting capacities shown on fully extended outriggers do not exceed 85% of the tipping loads and on tires do not exceed 75% of the tipping loads.

60,000 lb Counterweight – Fully Extended Outriggers – 360° Rotation (All Capacities Are Listed In Pounds)									
195.3 ft Main Boom Length									
Radius (ft)	31 ft Manual Offset Fly				55 ft Manual Offset Fly				Radius (ft)
	2°	15°	30°	45°	2°	15°	30°	45°	
50	10,800								50
55	10,800				8,300				55
60	10,800	10,800			8,300				60
65	10,800	10,800			8,300				65
70	10,800	10,800	10,900		8,300				70
75	10,800	10,800	10,900	11,100	8,300	8,400			75
80	10,800	10,800	10,900	11,100	8,300	8,300			80
85	10,800	10,800	10,900	11,100	8,300	8,200			85
90	10,800	10,800	10,900	11,100	8,300	8,200	7,400		90
95	10,800	10,800	10,900	11,100	8,300	8,100	7,300		95
100	10,800	10,800	10,900	11,100	8,300	8,000	7,300	6,800	100
105	10,100	10,400	10,800	11,100	8,300	7,900	7,200	6,800	105
110	9,300	9,700	10,000	10,300	8,300	7,800	7,100	6,800	110
115	8,600	9,000	9,300	9,600	8,300	7,700	7,100	6,700	115
120	8,000	8,300	8,600	8,900	7,700	7,600	7,000	6,700	120
125	7,400	7,700	8,000	8,200	7,100	7,600	7,000	6,700	125
130	6,800	7,100	7,400	7,600	6,600	7,000	6,900	6,700	130
135	6,300	6,600	6,800	7,000	6,000	6,500	6,900	6,600	135
140	5,800	6,000	6,300	6,500	5,600	6,000	6,400	6,600	140
145	5,300	5,500	5,800	6,000	5,100	5,500	5,900	6,300	145
150	4,800	5,100	5,300	5,500	4,700	5,100	5,500	5,800	150
155	4,400	4,600	4,900	5,000	4,300	4,600	5,000	5,300	155
160	4,000	4,200	4,400	4,500	3,900	4,200	4,600	4,800	160
165	3,600	3,800	4,000	4,100	3,500	3,800	4,200	4,400	165
170	3,300	3,500	3,600	3,700	3,100	3,500	3,800	4,000	170
175	2,900	3,100	3,200	3,300	2,800	3,100	3,400	3,600	175
180	2,600	2,800	2,900		2,500	2,800	3,000	3,200	180
185	2,300	2,400	2,500		2,200	2,500	2,700	2,800	185
190	2,000	2,100	2,200		1,900	2,100	2,400	2,500	190
195	1,700	1,800	1,900		1,600	1,800	2,000	2,100	195
200	1,500	1,600	1,600		1,300	1,600	1,700	1,800	200
205	1,200	1,300				1,300	1,400		205
210							1,200		210

This information is not for crane operation. Operator must refer to the in-cab information for crane operation. Rated lifting capacities shown on fully extended outriggers do not exceed 85% of the tipping loads and on tires do not exceed 75% of the tipping loads.

60,000 lb Counterweight – Fully Extended Outriggers – 360° Rotation (All Capacities Are Listed In Pounds)													
195.3 ft Main Boom Length													
Radius (ft)	73 ft Manual Offset Fly				91 ft Manual Offset Fly				109 ft Manual Offset Fly				Radius (ft)
	2°	15°	30°	45°	2°	15°	30°	45°	2°	15°	30°	45°	
65	6,700												65
70	6,700				5,200								70
75	6,700				5,200								75
80	6,700				5,200								80
85	6,700	6,800			5,200				3,100				85
90	6,700	6,800			5,200	5,200			3,100				90
95	6,700	6,800			5,200	5,200			3,100				95
100	6,700	6,800	6,900		5,200	5,200			3,100				100
105	6,700	6,800	6,900		5,200	5,200	5,300		3,100	3,100			105
110	6,700	6,800	6,800	6,200	5,200	5,200	5,200		3,100	3,100			110
115	6,700	6,800	6,800	6,100	5,200	5,200	5,000	4,600	3,100	3,100	3,100		115
120	6,200	6,600	6,700	6,000	5,200	5,200	4,900	4,400	3,100	3,100	2,900		120
125	5,600	6,000	6,500	5,800	4,800	5,200	4,700	4,300	3,100	3,100	2,700	2,400	125
130	5,000	5,400	6,000	5,700	4,300	4,800	4,500	4,200	2,900	2,900	2,500	2,300	130
135	4,500	4,900	5,400	5,600	3,800	4,300	4,400	4,000	2,500	2,700	2,400	2,200	135
140	4,000	4,400	4,900	5,300	3,400	3,800	4,200	3,900	2,000	2,500	2,200	2,000	140
145	3,600	4,000	4,400	4,800	2,900	3,300	3,800	3,800	1,600	2,100	2,100	1,900	145
150	3,100	3,500	3,900	4,300	2,500	2,900	3,400	3,700	1,200	1,700	2,000	1,800	150
155	2,700	3,100	3,500	3,800	2,100	2,500	3,000	3,300		1,300	1,700	1,600	155
160	2,400	2,700	3,100	3,400	1,800	2,100	2,600	2,900			1,300	1,500	160
165	2,000	2,300	2,700	3,000	1,400	1,800	2,200	2,500				1,300	165
170	1,600	2,000	2,300	2,600		1,400	1,800	2,100					170
175	1,300	1,600	2,000	2,200			1,500	1,700					175
180		1,300	1,600	1,800				1,400					180
185			1,300	1,500									185

This information is not for crane operation. Operator must refer to the in-cab information for crane operation. Rated lifting capacities shown on fully extended outriggers do not exceed 85% of the tipping loads and on tires do not exceed 75% of the tipping loads.

Hydraulic Offset Fly Attachment Lift Capacity Charts – Optional

20,000 lb Counterweight – Fully Extended Outriggers – 360° Rotation (All Capacities Are Listed In Pounds)																	
Main Boom + 10 ft Hydraulic Offset Fly (2°–45° Offsets)																	
Radius (ft)	Main Boom Length (ft)															Radius (ft)	
	42.3	55.0	70.0	85.0	100.0	115.0	130.0	145.0	155.0	160.0	170.0	175.0	180.3	185.0	195.3		
10	51,800	51,800															10
12	47,200	51,800	51,800														12
15	46,200	46,600	51,800	51,800													15
20	45,000	45,500	45,700	45,300	51000												20
25	44,400	44,600	44,900	44,600	43200	45,600	40,000										25
30	44,400	44,200	44,300	44,100	42800	41,800	40,000	35,900	28,500	24,000		15,200					30
35	44,400	44,100	43,900	43,600	41000	40,500	38,000	35,900	28,500	24,000	22,200	15,200	19,500	14,100	12,300		35
40	44,400	44,100	43,700	43,300	37200	36,700	34,500	35,700	28,500	24,000	22,200	15,200	19,500	14,100	12,300		40
45		41,900	43,000	42,900	34300	33,700	31,600	32,900	28,500	24,000	22,200	15,200	19,500	14,100	12,300		45
50		34,600	35,500	35,400	31500	30,900	29,000	30,400	28,000	24,000	22,200	15,200	19,500	14,100	12,300		50
55		28,900	30,700	29,900	29100	28,400	26,600	27,300	25,400	24,000	22,200	15,200	19,500	14,100	12,300		55
60			26,300	26,900	25200	24,600	23,900	22,900	22,400	22,300	22,200	15,200	19,500	14,100	12,300		60
65			22,700	23,300	23000	21,800	21,200	20,600	18,900	20,600	20,500	15,200	19,500	14,100	12,300		65
70			19,800	20,300	20300	20,300	19,600	19,200	16,200	18,200	17,600	15,200	17,100	14,100	12,300		70
75				17,800	18,100	17,900	17,100	17,200	13,800	16,400	15,400	15,200	14,900	14,100	12,300		75
80				15,800	16,100	15,900	15,700	15,100	11,800	14,600	13,300	13,800	12,800	13,300	12,300		80
85				14,000	14,300	14,100	13,900	13,300	10,000	12,800	11,500	12,000	11,000	11,500	11,100		85
90					12,700	12,500	12,300	11,700	8,500	11,200	10,000	10,500	9,500	10,000	9,500		90
95					11,300	11,100	10,900	10,400	7,100	9,900	8,600	9,100	8,100	8,600	8,200		95
100					10,100	9,900	9,700	9,100	5,900	8,600	7,400	7,900	6,900	7,400	7,000		100
105						8,800	8,600	8,000	4,900	7,600	6,300	6,800	5,900	6,300	5,900		105
110						7,800	7,600	7,100	3,900	6,600	5,400	5,900	4,900	5,400	4,900		110
115						7,000	6,700	6,200	3,100	5,700	4,500	5,000	4,100	4,500	4,100		115
120							6,000	5,400	2,300	4,900	3,700	4,200	3,300	3,700	3,300		120
125							5,200	4,700	1,600	4,200	3,000	3,500	2,600	3,000	2,600		125
130							4,600	4,000		3,600	2,400	2,800	1,900	2,400	1,900		130
135								3,400		3,000	1,800	2,200	1,300	1,800	1,300		135
140								2,900		2,400	1,200	1,700		1,200			140
145								2,400		1,900		1,200					145
150										1,400							150

This information is not for crane operation. Operator must refer to the in-cab information for crane operation. Rated lifting capacities shown on fully extended outriggers do not exceed 85% of the tipping loads and on tires do not exceed 75% of the tipping loads.

60,000 lb Counterweight – Fully Extended Outriggers – 360° Rotation (All Capacities Are Listed In Pounds)																
Main Boom + 10 ft Hydraulic Offset Fly (2°–45° Offsets)																
Radius (ft)	Main Boom Length (ft)															Radius (ft)
	42.3	55.0	70.0	85.0	100.0	115.0	130.0	145.0	155.0	160.0	170.0	175.0	180.3	185.0	195.3	
10	51,800	51,800														10
12	47,200	51,800	51,800													12
15	46,200	46,600	51,800	51,800												15
20	45,000	45,500	45,700	45,300	51000											20
25	44,400	44,600	44,900	44,600	43200	45,600	40,000									25
30	44,400	44,200	44,300	44,100	42800	41,800	40,000	35,900	28,500	24,000		15,200				30
35	44,400	44,100	43,900	43,600	41000	40,500	38,000	35,900	28,500	24,000	22,200	15,200	19,500	14,100	12,300	35
40	44,400	44,100	43,700	43,300	37200	36,700	34,500	35,700	28,500	24,000	22,200	15,200	19,500	14,100	12,300	40
45		44,100	43,700	43,200	34300	33,700	31,600	32,900	28,500	24,000	22,200	15,200	19,500	14,100	12,300	45
50		44,000	43,700	43,200	31500	30,900	29,000	30,400	28,000	24,000	22,200	15,200	19,500	14,100	12,300	50
55		42,100	43,700	43,200	29100	28,400	26,600	28,100	25,400	24,000	22,200	15,200	19,500	14,100	12,300	55
60			43,000	40,300	26900	26,200	24,500	26,100	23,100	22,300	22,200	15,200	19,500	14,100	12,300	60
65			37,900	37,600	25000	24,300	22,700	24,100	21,100	20,600	21,400	15,200	19,500	14,100	12,300	65
70			33,700	33,600	23400	22,500	21,000	22,300	19,300	19,100	20,000	15,200	18,600	14,100	12,300	70
75				30,100	21,800	20,900	19,500	20,700	17,600	17,700	18,600	15,200	16,600	14,100	12,300	75
80				27,000	20,500	19,500	18,100	19,200	16,400	16,700	17,400	15,200	16,000	14,100	12,300	80
85				24,400	19,300	18,300	17,200	17,800	15,100	15,600	16,400	14,800	14,700	14,100	12,300	85
90					18,200	17,200	16,000	16,800	13,800	14,600	15,400	13,800	13,600	13,800	12,300	90
95					17,200	16,200	15,000	15,600	12,700	13,600	14,500	12,900	12,500	12,800	12,000	95
100					16,500	15,300	14,000	14,600	11,600	12,700	13,500	12,100	11,500	11,800	11,100	100
105						14,400	13,100	13,600	10,700	11,900	12,700	11,300	10,600	10,900	10,200	105
110						13,500	12,300	12,600	9,800	11,200	11,800	10,600	9,800	10,100	9,400	110
115						12,800	11,500	11,700	9,000	10,500	11,100	9,900	9,000	9,300	8,600	115
120							10,800	10,900	8,200	9,800	10,400	9,300	8,300	8,600	7,900	120
125							10,300	9,800	7,500	9,200	9,700	8,700	7,600	7,900	7,200	125
130							9,800	9,000	6,800	8,700	9,100	8,100	7,000	7,300	6,600	130
135								8,500	6,200	8,200	8,500	7,600	6,400	6,700	6,000	135
140								8,000	5,600	7,700	8,000	7,100	5,800	6,100	5,400	140
145								7,600	5,100	7,200	7,300	6,700	5,300	5,600	4,900	145
150									4,500	6,800	6,600	6,200	4,800	5,100	4,400	150
155									4,100	6,400	6,000	5,800	4,300	4,700	4,000	155
165											4,800	5,100	3,500	3,800	3,100	165
170												4,700	3,100	3,400	2,700	170
175													2,700	3,100	2,400	175
180														2,700	2,000	180
185															1,700	185
190															1,400	190

This information is not for crane operation. Operator must refer to the in-cab information for crane operation. Rated lifting capacities shown on fully extended outriggers do not exceed 85% of the tipping loads and on tires do not exceed 75% of the tipping loads.

20,000 lb Counterweight – Fully Extended Outriggers – 360° Rotation (All Capacities Are Listed In Pounds)							
155.0 ft Main Boom Length							
Radius (ft)	31 ft Hydraulic Offset Fly			55 ft Hydraulic Offset Fly			Radius (ft)
	2°–15°	15°–30°	30°–45°	2°–15°	15°–30°	30°–45°	
40	18,700						40
45	17,400	17,400		12,900			45
50	17,100	15,200	15,200	12,600			50
55	16,800	15,000	13,700	10,500	10,500		55
60	16,500	14,800	13,600	10,300	10,300		60
65	16,300	14,600	13,500	10,000	10,000		65
70	16,000	14,400	13,400	9,800	8,500	8,500	70
75	14,700	14,200	13,300	9,600	8,300	8,300	75
80	12,600	13,700	13,200	9,400	8,200	7,400	80
85	10,900	11,800	12,800	9,200	8,000	7,300	85
90	9,300	10,200	11,100	9,000	7,900	7,200	90
95	7,900	8,800	9,600	8,800	7,800	7,200	95
100	6,700	7,500	8,200	7,900	7,700	7,100	100
105	5,700	6,400	7,000	6,800	7,600	7,100	105
110	4,700	5,400	6,000	5,900	7,000	7,000	110
115	3,900	4,400	5,000	5,000	6,000	7,000	115
120	3,100	3,600	4,100	4,200	5,200	6,100	120
125	2,400	2,900	3,300	3,500	4,400	5,300	125
130	1,700	2,200	2,600	2,800	3,600	4,500	130
135		1,500	1,900	2,200	3,000	3,700	135
140			1,300	1,600	2,400	3,000	140
145					1,800	2,400	145
150					1,300	1,800	150
155						1,800	155

This information is not for crane operation. Operator must refer to the in-cab information for crane operation. Rated lifting capacities shown on fully extended outriggers do not exceed 85% of the tipping loads and on tires do not exceed 75% of the tipping loads.

60,000 lb Counterweight – Fully Extended Outriggers – 360° Rotation (All Capacities Are Listed In Pounds)							
155.0 ft Main Boom Length							
Radius (ft)	31 ft Hydraulic Offset Fly			55 ft Hydraulic Offset Fly			Radius (ft)
	2°–15°	15°–30°	30°–45°	2°–15°	15°–30°	30°–45°	
40	18,700						40
45	17,400	17,400		12,900			45
50	17,100	15,200	15,200	12,600			50
55	16,800	15,000	13,700	10,500	10,500		55
60	16,500	14,800	13,600	10,300	10,300		60
65	16,300	14,600	13,500	10,000	10,000		65
70	16,000	14,400	13,400	9,800	8,500	8,500	70
75	15,700	14,200	13,300	9,600	8,300	8,300	75
80	15,100	14,000	13,200	9,400	8,200	7,400	80
85	13,900	13,800	13,100	9,200	8,000	7,300	85
90	12,800	13,200	13,000	9,000	7,900	7,200	90
95	11,800	12,200	12,600	8,800	7,800	7,200	95
100	10,800	11,200	11,600	8,600	7,700	7,100	100
105	10,000	10,300	10,700	8,400	7,600	7,100	105
110	9,200	9,500	9,800	8,300	7,500	7,000	110
115	8,400	8,700	9,100	8,100	7,400	7,000	115
120	7,700	8,000	8,300	7,700	7,300	7,000	120
125	7,100	7,300	7,600	7,000	7,200	6,900	125
130	6,400	6,700	7,000	6,400	6,900	6,900	130
135	5,900	6,100	6,300	5,900	6,300	6,700	135
140	5,300	5,600	5,800	5,400	5,700	6,100	140
145	4,800	5,000	5,200	4,900	5,200	5,600	145
150	4,400	4,500	4,700	4,400	4,800	5,100	150
155	3,900	4,100	4,200	4,000	4,300	4,600	155
160	3,500	3,700	3,700	3,600	3,900	4,100	160
165	3,100	3,200		3,200	3,500	3,700	165
170	2,800	2,900		2,800	3,100	3,300	170
175	2,500	2,500		2,500	2,700	2,900	175
180				2,200	2,400	2,500	180
185				1,900	2,000	2,100	185
190				1,600	1,700	1,800	190
195				1,400			195

This information is not for crane operation. Operator must refer to the in-cab information for crane operation. Rated lifting capacities shown on fully extended outriggers do not exceed 85% of the tipping loads and on tires do not exceed 75% of the tipping loads.

60,000 lb Counterweight – Fully Extended Outriggers – 360° Rotation (All Capacities Are Listed In Pounds)										
155.0 ft Main Boom Length										
Radius (ft)	73 ft Hydraulic Offset Fly			91 ft Hydraulic Offset Fly			109 ft Hydraulic Offset Fly			Radius (ft)
	2°–15°	15°–30°	30°–45°	2°–15°	15°–30°	30°–45°	2°–15°	15°–30°	30°–45°	
50	11,000									50
55	11,000			8,400						55
60	9,800	9,800		8,400			6,500			60
65	9,600	9,600		8,400	8,400		6,500			65
70	9,500	9,500		8,300	8,300		6,300	6,300		70
75	9,300	8,200	8,200	7,900	7,900		5,900	5,900		75
80	9,100	8,000	8,000	7,400	6,500	6,500	5,500	5,500		80
85	9,000	7,900	6,900	7,000	6,100	6,100	5,200	4,600	4,600	85
90	8,800	7,600	6,600	6,600	5,800	5,300	4,800	4,300	4,300	90
95	8,600	7,300	6,400	6,300	5,500	5,000	4,500	4,000	3,700	95
100	8,200	7,000	6,200	6,000	5,200	4,800	4,200	3,800	3,500	100
105	7,900	6,700	6,000	5,700	5,000	4,500	3,900	3,500	3,300	105
110	7,600	6,500	5,800	5,400	4,700	4,300	3,700	3,300	3,000	110
115	7,300	6,300	5,700	5,100	4,500	4,100	3,400	3,100	2,800	115
120	7,000	6,100	5,500	4,900	4,300	4,000	3,200	2,800	2,600	120
125	6,800	5,900	5,400	4,600	4,100	3,800	3,000	2,600	2,400	125
130	6,300	5,700	5,200	4,400	3,900	3,600	2,700	2,400	2,200	130
135	5,700	5,500	5,100	4,200	3,700	3,500	2,600	2,300	2,100	135
140	5,200	5,400	5,000	4,000	3,600	3,300	2,400	2,100	1,900	140
145	4,700	5,100	4,900	3,800	3,400	3,200	2,200	1,900	1,800	145
150	4,200	4,600	4,800	3,600	3,300	3,100	2,000	1,800	1,600	150
155	3,800	4,100	4,500	3,300	3,100	3,000	1,900	1,600	1,500	155
160	3,300	3,700	4,100	2,900	3,000	2,900	1,700	1,500	1,300	160
165	2,900	3,300	3,600	2,500	2,800	2,800	1,600	1,300	1,200	165
170	2,600	2,900	3,200	2,100	2,400	2,700	1,400	1,200		170
175	2,200	2,500	2,800	1,800	2,100	2,400	1,300			175
180	1,800	2,100	2,400	1,400	1,700	2,000				180
185	1,500	1,700	2,000		1,300	1,700				185
190	1,200	1,400	1,600			1,300				190
195			1,200							195

This information is not for crane operation. Operator must refer to the in-cab information for crane operation. Rated lifting capacities shown on fully extended outriggers do not exceed 85% of the tipping loads and on tires do not exceed 75% of the tipping loads.

20,000 lb Counterweight – Fully Extended Outriggers – 360° Rotation (All Capacities Are Listed In Pounds)							
195.3 ft Main Boom Length							
Radius (ft)	31 ft Hydraulic Offset Fly			55 ft Hydraulic Offset Fly			Radius (ft)
	2°–15°	15°–30°	30°–45°	2°–15°	15°–30°	30°–45°	
50	10,500						50
55	10,500	10,500		8,000			55
60	10,500	10,500		8,000			60
65	10,500	10,500	10,700	8,000			65
70	10,500	10,500	10,700	8,000	8,100		70
75	10,500	10,500	10,700	8,000	8,100		75
80	10,500	10,500	10,700	8,000	8,100		80
85	10,500	10,500	10,700	8,000	7,200	7,200	85
90	9,900	10,500	10,700	7,900	7,200	7,200	90
95	8,600	9,400	10,200	7,800	7,100	7,100	95
100	7,300	8,100	8,900	7,700	7,000	6,600	100
105	6,300	7,000	7,700	7,100	7,000	6,600	105
110	5,300	6,000	6,600	6,100	6,900	6,500	110
115	4,400	5,100	5,700	5,200	6,300	6,500	115
120	3,600	4,200	4,800	4,400	5,400	6,500	120
125	2,900	3,500	4,000	3,700	4,700	5,600	125
130	2,300	2,800	3,300	3,000	3,900	4,800	130
135	1,700	2,200	2,600	2,400	3,300	4,100	135
140		1,600	2,000	1,800	2,700	3,400	140
145			1,400	1,300	2,100	2,800	145
150					1,600	2,200	150
155						1,700	155
160						1,200	160

This information is not for crane operation. Operator must refer to the in-cab information for crane operation. Rated lifting capacities shown on fully extended outriggers do not exceed 85% of the tipping loads and on tires do not exceed 75% of the tipping loads.

60,000 lb Counterweight – Fully Extended Outriggers – 360° Rotation (All Capacities Are Listed In Pounds)							
195.3 ft Main Boom Length							
Radius (ft)	31 ft Hydraulic Offset Fly			55 ft Hydraulic Offset Fly			Radius (ft)
	2°–15°	15°–30°	30°–45°	2°–15°	15°–30°	30°–45°	
50	10,500						50
55	10,500	10,500		8,000			55
60	10,500	10,500		8,000			60
65	10,500	10,500	10,700	8,000			65
70	10,500	10,500	10,700	8,000	8,100		70
75	10,500	10,500	10,700	8,000	8,100		75
80	10,500	10,500	10,700	8,000	8,100		80
85	10,500	10,500	10,700	8,000	7,200	7,200	85
90	10,500	10,500	10,700	7,900	7,200	7,200	90
95	10,500	10,500	10,700	7,800	7,100	7,100	95
100	9,900	10,300	10,700	7,700	7,000	6,600	100
105	9,100	9,500	9,900	7,600	7,000	6,600	105
110	8,400	8,800	9,100	7,500	6,900	6,500	110
115	7,700	8,100	8,400	7,400	6,800	6,500	115
120	7,100	7,400	7,700	6,800	6,800	6,500	120
125	6,400	6,800	7,100	6,200	6,700	6,500	125
130	5,900	6,200	6,500	5,700	6,100	6,400	130
135	5,300	5,600	5,900	5,100	5,600	6,100	135
140	4,800	5,100	5,400	4,700	5,100	5,600	140
145	4,300	4,600	4,900	4,200	4,600	5,000	145
150	3,900	4,100	4,400	3,800	4,200	4,600	150
155	3,500	3,700	3,900	3,300	3,700	4,100	155
160	3,100	3,300	3,500	2,900	3,300	3,700	160
165	2,700	2,900	3,100	2,600	2,900	3,300	165
170	2,300	2,500	2,700	2,200	2,500	2,900	170
175	2,000	2,100	2,300	1,900	2,200	2,500	175
180	1,600	1,800	1,900	1,500	1,800	2,100	180
185	1,300	1,500	1,600	1,200	1,500	1,700	185
190			1,200		1,200	1,400	190

This information is not for crane operation. Operator must refer to the in-cab information for crane operation. Rated lifting capacities shown on fully extended outriggers do not exceed 85% of the tipping loads and on tires do not exceed 75% of the tipping loads.

60,000 lb Counterweight – Fully Extended Outriggers – 360° Rotation
(All Capacities Are Listed In Pounds)

195.3 ft Main Boom Length

Radius (ft)	73 ft Hydraulic Offset Fly			91 ft Hydraulic Offset Fly			109 ft Hydraulic Offset Fly			Radius (ft)
	2°–15°	15°–30°	30°–45°	2°–15°	15°–30°	30°–45°	2°–15°	15°–30°	30°–45°	
65	6,500									65
70	6,500			5,000						70
75	6,500	6,600		5,000						75
80	6,500	6,600		5,000	5,000					80
85	6,500	6,600		5,000	5,000		3,000			85
90	6,500	6,600		5,000	5,000		3,000			90
95	6,500	6,600	6,700	5,000	5,000		3,000			95
100	6,500	6,600	6,700	5,000	4,800	4,800	3,000	3,000		100
105	6,500	6,500	5,600	5,000	4,600	4,600	3,000	3,000	3,000	105
110	6,500	6,300	5,500	5,000	4,400	3,900	3,000	2,800	2,800	110
115	5,800	6,100	5,300	4,900	4,200	3,700	3,000	2,600	2,600	115
120	5,200	5,600	5,200	4,300	4,000	3,600	2,900	2,400	2,000	120
125	4,600	5,000	5,000	3,800	3,800	3,400	2,700	2,300	2,000	125
130	4,000	4,500	4,900	3,300	3,700	3,300	2,500	2,100	1,800	130
135	3,500	3,900	4,400	2,800	3,200	3,100	2,000	1,900	1,700	135
140	3,000	3,400	3,900	2,300	2,800	3,000	1,500	1,800	1,500	140
145	2,500	2,900	3,400	1,900	2,300	2,800		1,600	1,400	145
150	2,100	2,500	3,000	1,500	1,900	2,400		1,200	1,300	150
155	1,700	2,100	2,500		1,400	1,900				155
160	1,300	1,700	2,100			1,500				160
165		1,300	1,700							165
170			1,300							170

This information is not for crane operation. Operator must refer to the in-cab information for crane operation. Rated lifting capacities shown on fully extended outriggers do not exceed 85% of the tipping loads and on tires do not exceed 75% of the tipping loads.

This Page Intentionally Blank

This Page Intentionally Blank

Link-Belt Construction Equipment Company Lexington, Kentucky www.linkbelt.com

®Link-Belt is a registered trademark. Copyright 2015. We are constantly improving our products and therefore reserve the right to change designs and specifications.